



99-95530004 - ISSUE 1-2

ENGLISH

DRUM CUTTER OPERATORS MANUAL

KDC30

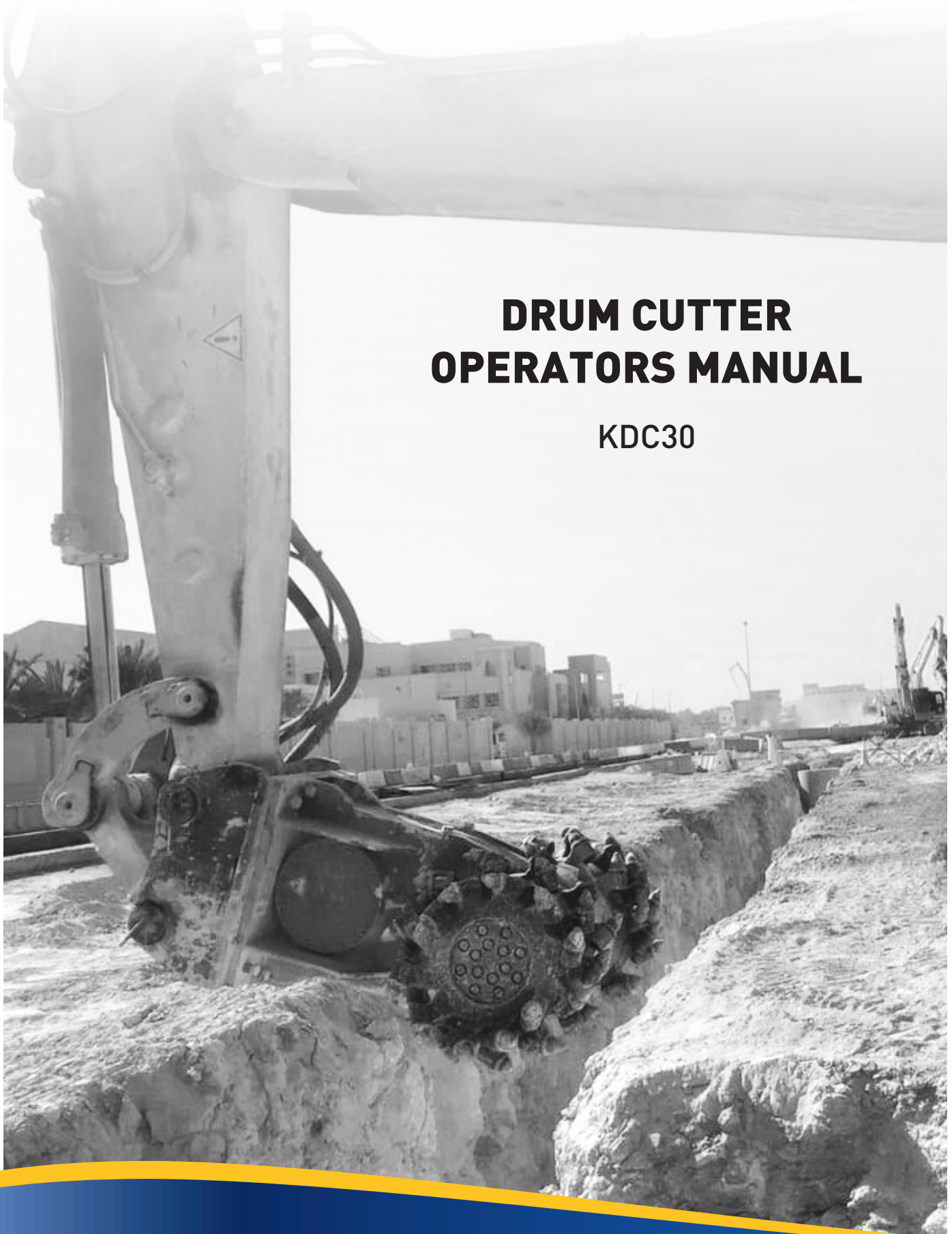

www.augertorque.com

Please complete before commissioning the cutting unit:



Auger Torque Europe Ltd
Hazleton
Cheltenham
GL54 4DX
England
Tel: +44 (0) 1451 861652
Fax: +44 (0) 1451 861660
Email: sales@augertorque.com

Auger Torque Australia Pty Ltd
481 Boundary Rd
Dara
Queensland 4076
Australia
Tel: +61 (0) 7 3274 2077
Fax: +61 (0) 7 3274 5077
Email: sales@augertorque.com.au

Auger Torque USA LLC
2640 Jason Industrial Parkway
Winston, GA 30187
USA
Tel: (+1) 844 287 6300
Fax: (+1) 770 947 9916
Email: sales@augertorqueusa.com

MODEL NUMBER:

SERIAL NUMBER:

DATE OF MANUFACTURE:

SUPPLIER / DEALER:

DATE SOLD TO SUPPLIER / DEALER:

DATE SOLD TO ORIGINAL END USER:

OWNER OR OPERATOR:

PARENT MACHINE MAKE & MODEL:

1 Table of contents

2 Foreword

- 2.1 Concerning these operating instructions
- 2.2 Notes on using the Operating Instructions
- 2.3 Definition of target groups
- 2.4 Proper use of the transverse cutting unit
- 2.5 Improper use of the transverse cutting unit

3 Safety

- 3.1 General Safety
 - 3.1.1 Safety Symbol
 - 3.1.2 Hazard classification
 - 3.1.3 Descriptions of symbols and hazard pictorials
 - 3.1.4 Locations of safety signs
 - 3.1.5 Service and replacement of safety signs
- 3.2 Personal safety
 - 3.2.1 Personal safety gear
- 3.3 Work zone safety
 - 3.3.1 General work zone regulations – safe work practices
 - 3.3.2 Deactivation and protection against re-activation
- 3.4 Vibration

4 Installation

- 4.1 Adapter bracket
 - 4.1.1 Details of the adapter bracket
- 4.2 Standard hydraulic connection
 - 4.2.1 Hydraulic hoses
 - 4.2.2 Hydraulic plan – Non-return valve
 - 4.2.3 Hydraulic oil
- 4.3 Contamination and filtration
- 4.4 Priming (filling) the hydraulic motor casing
 - 4.4.1 Checking the oil level
 - 4.4.2 Topping up hydraulic oil
- 4.5 Before initial start-up
- 4.6 Hydraulic transverse cutting units installation and commissioning report

5 Operation

- 5.1 Description
- 5.2 Examples of Using Cutting Unit
 - 5.2.1 Using Cutting Unit in narrow Ditches
 - 5.2.2 Using Cutting Unit with Asphalt
 - 5.2.3 Using Cutting Unit on Walls
 - 5.2.4 Using Cutting Unit under Water
- 5.3 Cutting drum selection
 - 5.3.1 Excavating drum
 - 5.3.2 Profilling drum
 - 5.3.3 Demolition drum

- 5.4 Examples of tooth types
 - 5.4.1 Standard tooth
 - 5.4.2 Heavy-duty tooth
 - 5.4.3 Wear-protected tooth
 - 5.4.4 Wood-cutting tooth
- 5.5 Regulations concerning environmental protection
- 6 Maintenance and Care**
 - 6.1 Maintenance plan
 - 6.2 Gearbox oil level
 - 6.3 Lubrication
 - 6.3.1 Grease nipple
 - 6.4 Screwed connections – tightening torques
 - 6.5 Checking the condition of the hydraulic motor
 - 6.6 Replacing the teeth on the cutting drums
 - 6.6.1 Removing teeth
 - 6.6.2 Installing teeth
- 7 Transport**
 - 7.1 Delivery
 - 7.2 Packing
 - 7.3 Transport of the packed cutting unit
 - 7.4 Transport of the unpacked cutting unit
 - 7.4.1 Transport by crane
- 8 Technical data**
 - 8.1 **KDC30-HD** specifications (displacement - 6012 cm³ (2369 in³))
- 9 Trouble-shooting**
- 10 Warranty and liability**
- 11 EC Declaration of conformity**
- 12 Locations**

2 Foreword

2.1 Concerning these operating instructions

Please read this instruction manual carefully so that you are acquainted with the correct handling and operation.

The operator must also follow the enclosed operating instructions for externally supplied components.

Observe the national legal and miscellaneous regulations.

All target groups must have read these Operations Instructions and understood their contents.

Contact our customer service if you have any questions concerning the operator's manuals:

Auger Torque Europe Ltd

Hazleton
Cheltenham
GL54 4DX
England
Tel: +44 (0) 1451 861652
Fax: +44 (0) 1451 861660
Email: sales@augertorque.com

Auger Torque Australia Pty Ltd

481 Boundary Rd
Dara
Queensland 4076
Australia
Tel: +61 (0) 7 3274 2077
Fax: +61 (0) 7 3274 5077
Email: sales@augertorque.com.au

Auger Torque USA LLC

2640 Jason Industrial Parkway
Winston, GA 30187
USA
Tel: (+1) 844 287 6300
Fax: (+1) 770 947 9916
Email: sales@augertorqueusa.com

2.2 Notes on using the Operating Instructions

Structure of safety notes

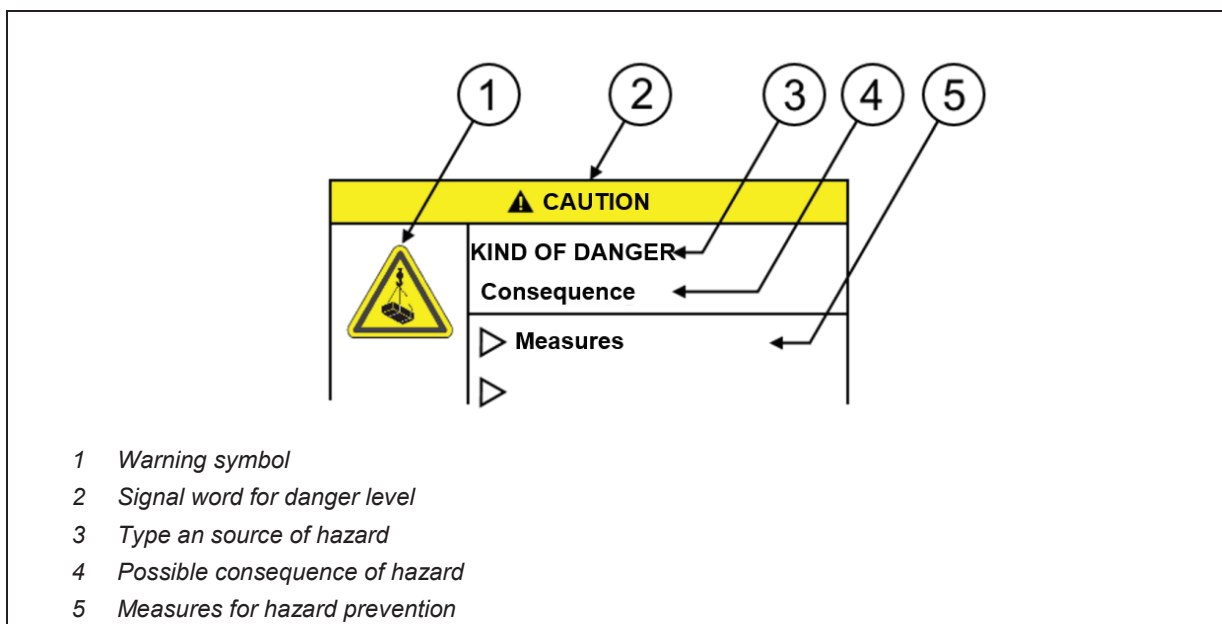

This symbol is employed for information containing important notes about the correct use and/or how to proceed. Noncompliance may lead to malfunction.

2.3 Definition of target groups

The contents of these Operating Instructions are aimed at a diverse target audience. The level of knowledge each target group must have is defined here. All target groups must have read these Operations Instructions and understood their contents.

Operating personnel must

- be of the legal minimum age.
- have been instructed in the use of the machine.
- be familiar with the country-specific accident-prevention regulations.

Maintenance personnel must

- be of the legal minimum age.
- know the maintenance points on the machine.
- know the country-specific environmental regulations for the disposal of lubricants (see chapter **Regulations concerning environmental protection**).

Service personnel must

- be of the legal minimum age.
- have sound school education and vocational training.
- have been instructed by Auger Torque in the performance of service jobs on the machine.
- must have been trained in the rules and procedures related to a case of malfunction.

2.4 Proper use of the transverse cutting unit

The transverse cutting unit is available with a wide range of hydraulic motors and cutting drums featuring different tooth configurations suitable for most applications.

- Ensure that the maintenance schedule has been adhered to before operating the machine.
- The machine must only be run by well-trained operating personnel with competent knowledge.
- The machine must only be maintained by well-trained maintenance personnel with competent knowledge.
- Operate the handles smoothly without jerking. If the cutting head stalls, back off the cutter from the workface. Do not overload the teeth as this may cause damage to the cutting unit.
- Periodically check that the cutting head is clear of debris as this can affect the overall cutting rate and wear and tear of the tool.
- Always ensure that the cutting unit or any part of the unit is correctly attached during any maintenance work.
- Our Technical Service has to be consulted before the cutting unit is used in wet environments or under water. Before the cutting unit can be used in such environments it has to be converted (see chapter Operation under water).

2.5 Improper use of the transverse cutting unit

- Do not operate the cutting unit at the stroke end of a hydraulic cylinder of the attachment carrier.
- Do not use the cutting drum with damaged or missing teeth as this causes vibration and may damage the unit or excavator.
- The cutting unit should never be run in reverse rotation during use, (unless it can be done so hydraulically), as this can cause damage to the motor.
- Never try to cut with the unit when switched off and while tracking the excavator as this may cause damage to the unit.
- Never place the cutting head against the working surface before starting the cutting unit as this may damage the unit. The unit must be running and fed into the working surface at a rate that does not allow stalling..

3 Safety



3.1 General safety

3.1.1 Safety symbol

	The safety symbol is used to warn you of potential personal injury. Observe all instructions that follow this safety symbol in order to avoid potential injuries or death.
---	---







3.1.2 Hazard classification

The precautionary statements are divided into four categories:

 DANGER	Indicates a hazardous situation which, if not avoided will result in death or serious injury .
 WARNING	Indicates a hazardous situation which, if not avoided could result in death or serious injury .
 CAUTION	Indicates a hazardous situation which, if not avoided could result in minor or moderate injury .
NOTICE	Without safety symbol – indicates a situation which, if not avoided could result in property damage .

3.1.3 Descriptions of symbols and hazard pictorials

The symbols used in this Manual and on the machine identify the following hazards:

Symbol	Meaning
	WARNING OF PROPERTY DAMAGE Indicates a situation which, if not avoided could result in property damage .
	WARNING OF A HAZARDOUS SPOT If the required precautionary measures are not taken, death, personal injury, and substantial property or equipment damage may occur.
	WARNING OF CUTTING UNIT DRUM If the required precautionary measures are not taken, the transverse cutting unit may cause personal injury and substantial property or equipment damage.
	WARNING OF ENVIRONMENTALLY HAZARDOUS SUBSTANCES If the required precautionary measures are not taken, these substances may cause serious environmental damage.
	WARNING OF CRUSHING DANGER If the required precautionary measures are not taken, personal injury due to crushing may occur.
	WARNING OF SUSPENDED LOAD If the required precautionary measures are not taken, death, personal injury, and substantial property or equipment damage may occur due to suspended or falling loads.

3.1.4 Locations of safety signs

The safety signs are located in the following machine positions:

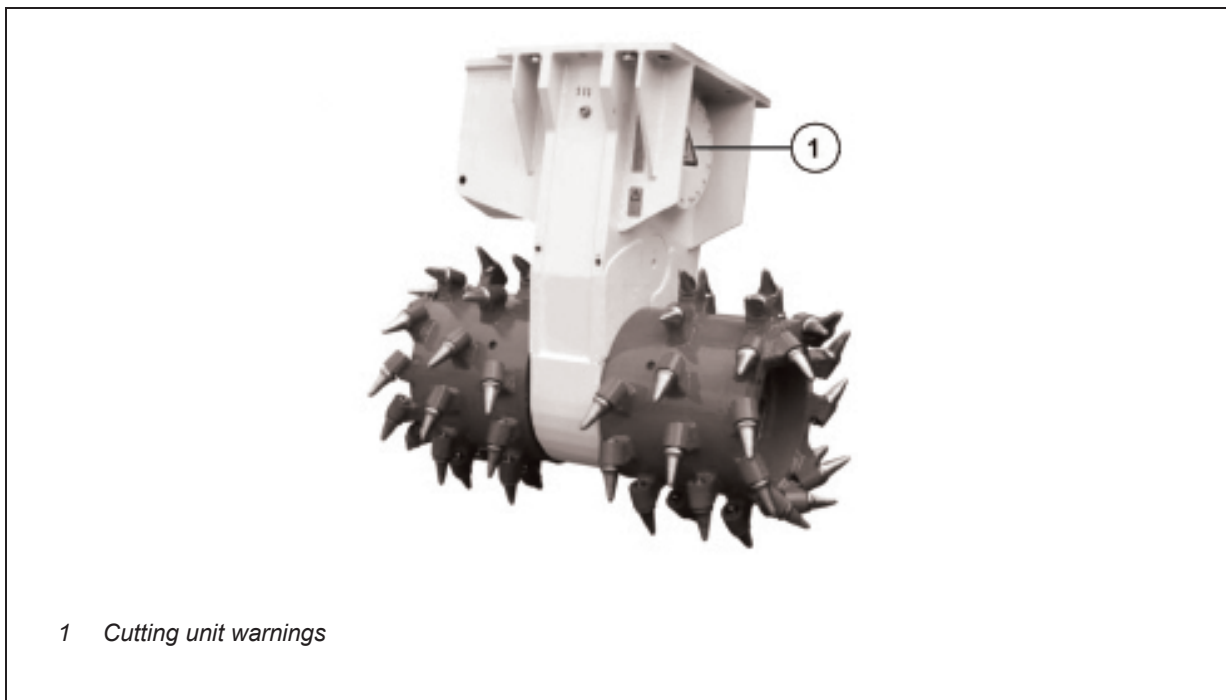

3.1.5 Service and replacement of safety signs



- The safety of the operator always has to come first.
- Replace any safety sign which has been damaged or disappeared.
- Use mild detergents and water to clean the safety signs.
- Do not use detergents containing solvents.

3.2 Personal safety

The Operating Instructions and the symbols described have to be read and understood by all persons working on and with the machine.

3.2.1 Personal safety gear

The following mandatory signs used in this manual and on the machine inform the user that these safety measures are required **at all times on the work site**:

Symbol	Meaning
	Wear Protective Clothing
	Wear Protective Gloves
	Wear Protective Goggles
	Wear Hearing Protection
	Wear Safety Shoes
	Wear Safety Helmet
	Wear a Hairnet with Long, Open Hair
	Do not wear loose clothing, which may get entangled in the machine

3.3 Work zone safety

3.3.1 General work zone regulations – safe work practices

Obtain information on routine machine checks and consult the relevant authorities with regard to work regulations.

The cutting unit does not incorporate any feature for dust suppression as standard equipment. The low cutting speed and type of strata generally excavated combine to reduce dust to minimal levels. However, in those circumstances, where excessive dust levels are generated, appropriate counter measures must be adopted, for example water spray systems or mobile/stationary anti-dust systems and the use of personal protective equipment.

3.3.2 Deactivation and protection against re-activation

Ensure all the following safety instructions are read prior to using or servicing the cutting unit, to avoid personal injury.

- Ensure the area is clear of personnel before and during operation of the cutting unit. The cutting unit will produce small fragments that can be forcibly ejected and may cause injuries. Ensure no personnel or equipment are within this area. As soon as someone enters this zone, stop the cutting operation and turn off the engine of the excavator.
- When leaving the excavator, place the cutting head on the ground and turn off the engine.
- Never touch the cutting unit whilst the cutting drums are rotating.
- Always stop the engine and remove the keys when inspecting or servicing the cutting unit.
- Do not adjust hydraulic valves or any part of the hydraulic system while the machine is running.
- Always change frayed, crushed or damaged hoses immediately.
- Always use original **Auger Torque** spare parts and change at once if damaged.

3.4 Vibration

WARNING	
	<p>DANGER CAUSED BY VIBRATION Vibration can damage health.</p>
	<p>▷ Do not exceed the specified labour time per day.</p>

Exposure limits and provocation values acc. to directive 2002/44/EC

For vibration of the whole body

- the daily exposure limit, standardized to a reference time of **8 hours**, is fixed to **1.15 m/s² (3.77 ft/s²)** or, if desired by a member state, to a vibration dose value of **21 m/s^{1.75} (68.90 ft/s²)**.
- the daily provocation value, standardized to a reference time of **8 hours**, is fixed to **0.5 m/s² (1.64 ft/s²)** or, if desired by a member state, to a vibration dose value of **9.1 m/s^{1.75} (29.86 ft/s^{1.75})**.

Milling operations generate vibrations, which are transferred to work equipment and operator. The intensity of these vibrations differs in dependence on the material to be processed. The maximum time the operator may be exposed to these vibrations is specified in the following table.

Intensity of vibrations	Material	Labour time in hours per day
light	e.g. soil	8
medium intensity	e.g. sandstone	6
intense	e.g. hard rock	4

4 Installation

4.1 Adapter bracket

The cutting unit requires an **adapter bracket** in order to fit onto the excavator. The **adapter bracket** of the cutting unit uses the existing bearing points and pins of the excavator. The cutting drums are designed to rotate clockwise in normal use - counter clockwise, toward the excavator - when looking at the machine as shown below, i.e. the hydraulic motor will be on the right-hand side looking from the driver's cab.

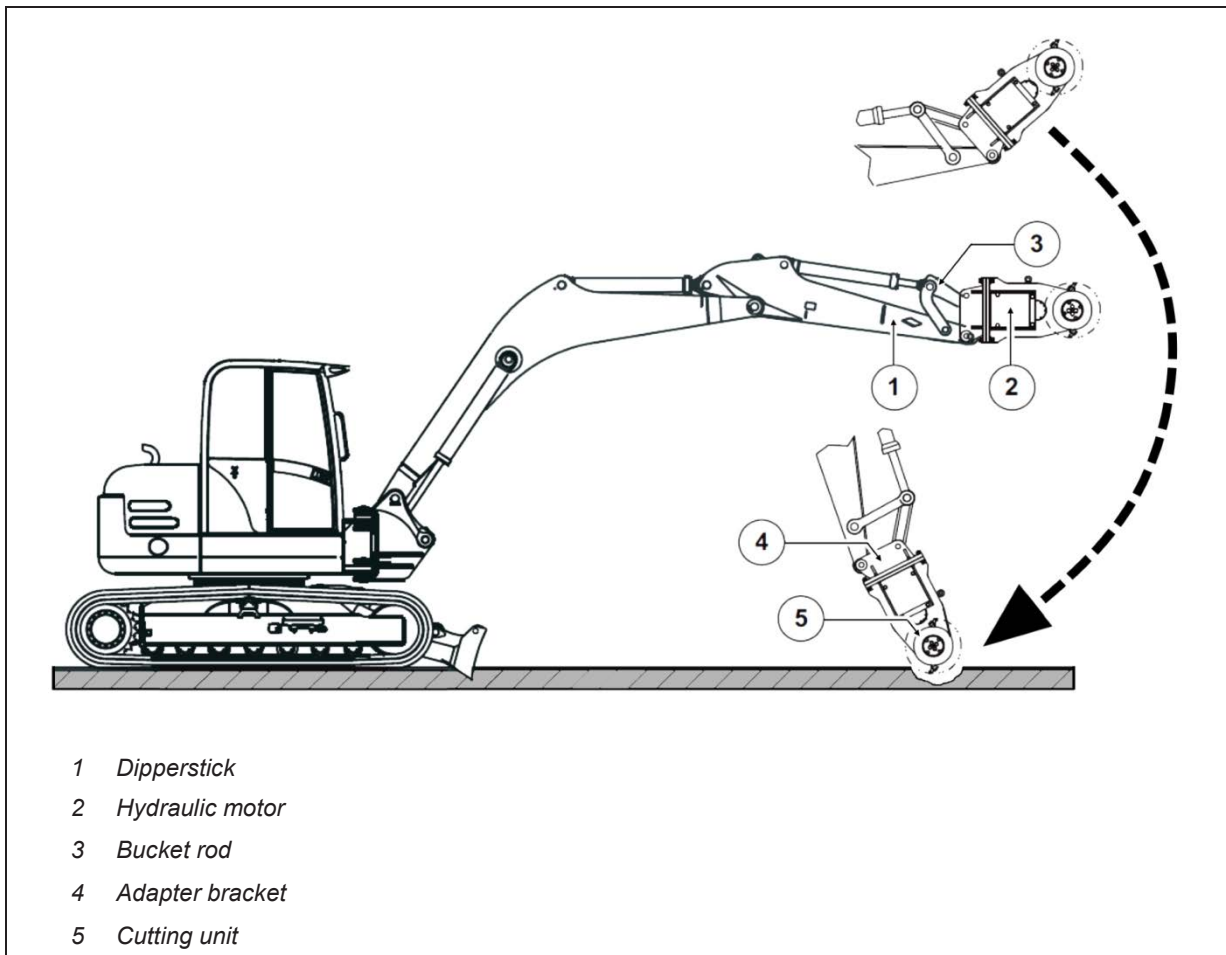

4.1.1 Details of the adapter bracket

The following drawing contains all specifications for the manufacture of an adapter bracket:

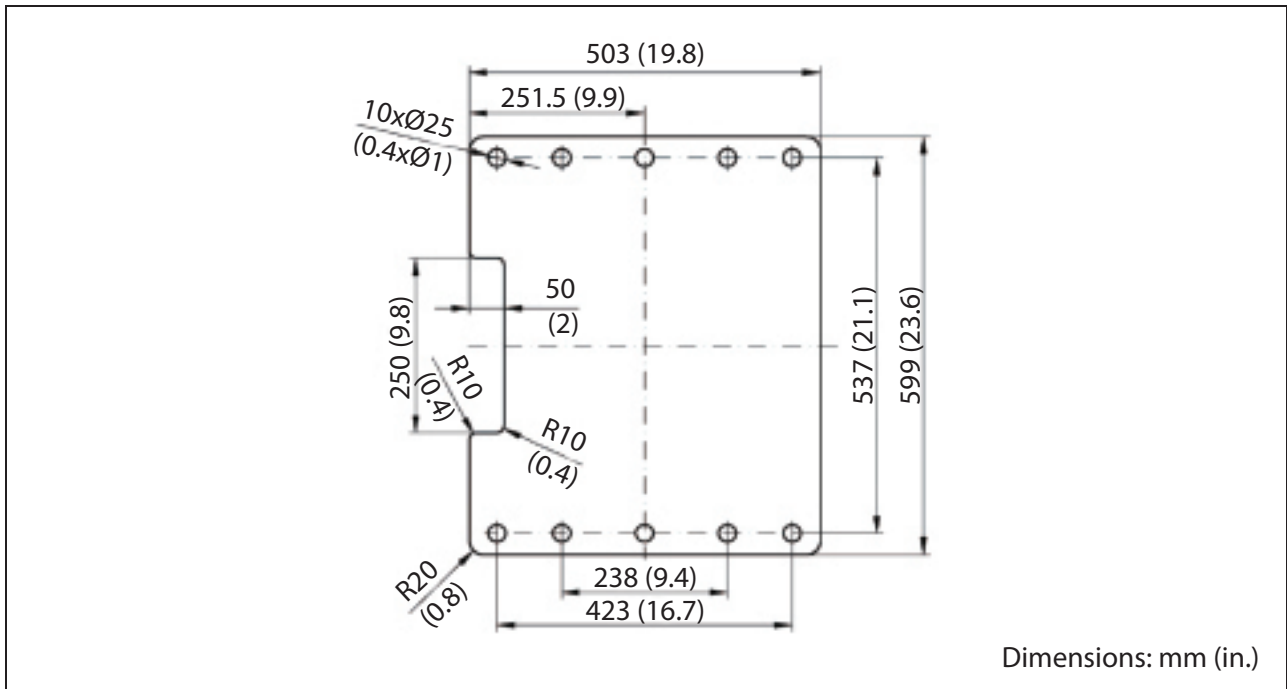

i The adapter bracket must have a thickness of 40 mm (1.6 in.) and be welded by expert personnel.

The following drawing contains all specifications for the manufacture of an adapter bracket:

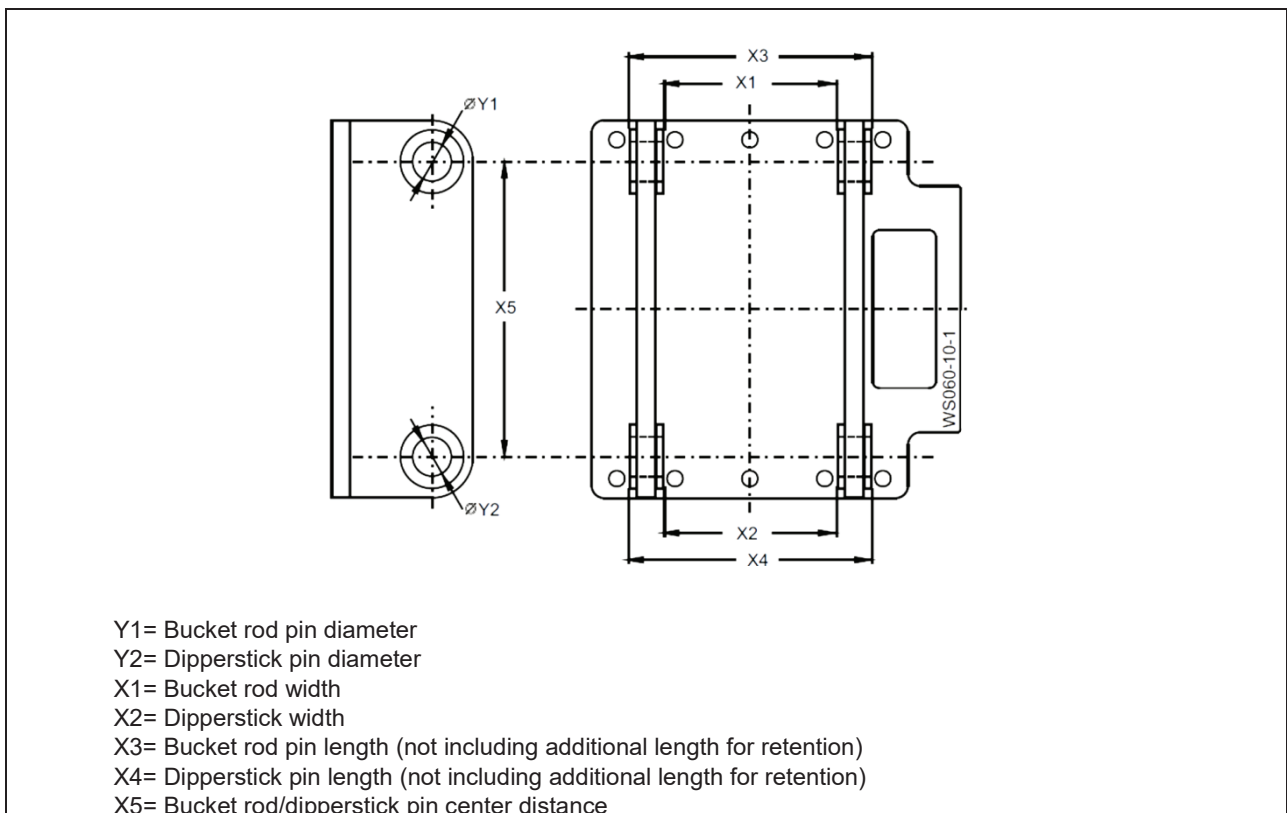

4.2 Standard hydraulic connection

Connect the transverse cutting unit to the hydraulic circuit in the following way:

NOTICE	
	<p>DANGER DUE TO INSUFFICIENT PRESSURE DIFFERENTIAL The hydraulic motor may be damaged.</p> <p>▷ If the pressure differential between the return line pressure and the leak-oil pressure is insufficient, the transverse cutting unit becomes very noisy during operation (rattling).</p> <p>▷ Call Service Personnel.</p>

- Connect the pressure line to the excavator.
- Connect the return line to the excavator.
- Connect the leak-oil line to the excavator.

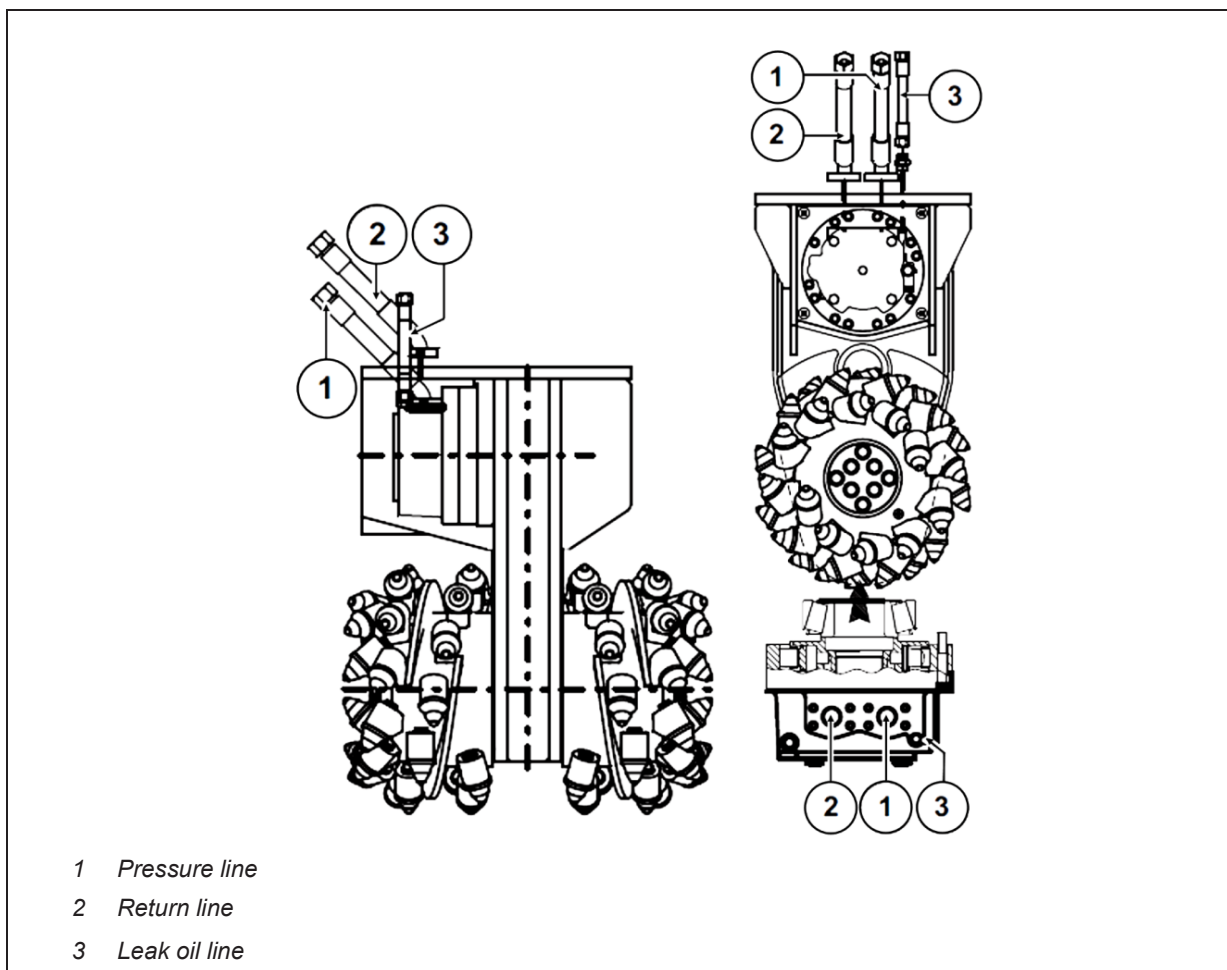

4.2.1 Hydraulic hoses

Pressure and return line connection	
on hydraulic motor	SAE 1 1/4" 6000PSI
to the excavator	ÜM30-S; M42x2
hose inner diameter	DN Ø25 (1")
minimum operating pressure	375 bar (5439 psi)
Leak-oil line	
on hydraulic motor	3/4-16UNF
to the excavator r	UM12-L; M18x1,5
hose inner diameter	DN Ø10 (0.4")

i *The pressure in the leak-oil line (T) is never to exceed 3 bar (43 psi) in continuous operation and temporary pressure peaks of 10 bar (145 psi). A non - return valve (R) with a preload of 8 bar (116 psi) is installed for safety reasons.*

4.2.2 Hydraulic plan – Non-return valve

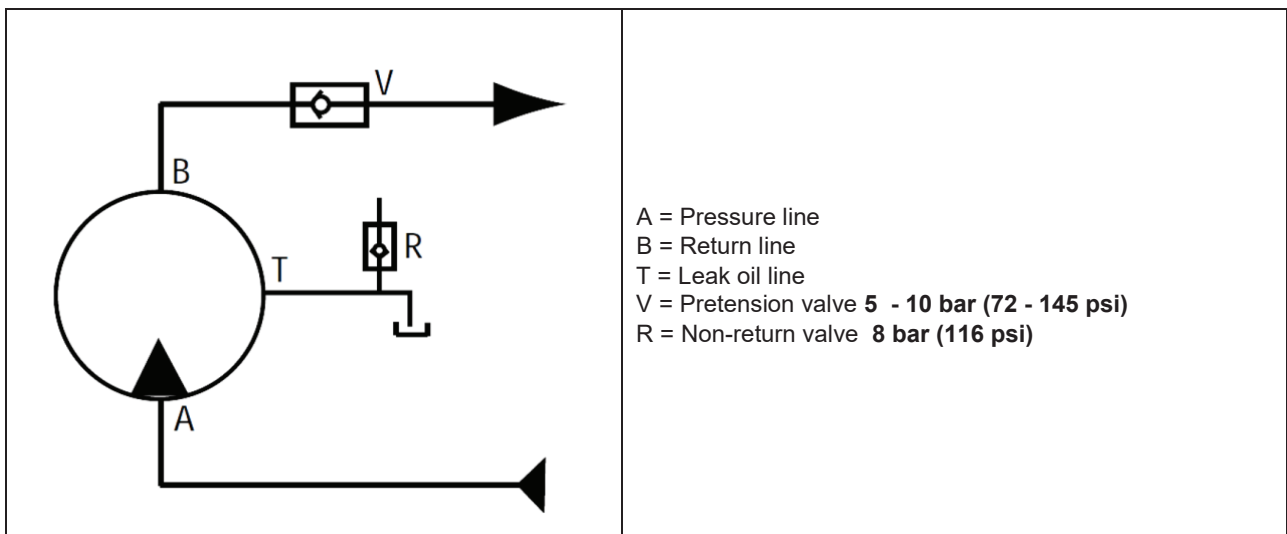

4.2.3 Hydraulic oil

- Oil type **HV 46** or **68**
- HV mineral oils possessing improved viscosity / temperature properties (**DIN 50524, Part 3**)
- Bio-degradable oil

i *Please contact Auger Torque before using any other hydraulic oil. Any other hydraulic oils must be approved in writing.*

4.2.4 Contamination and filtration

A low level of contamination of the hydraulic oil will ensure that the moving parts of the hydraulic motor (pistons, distributor) have a longer service life.
A contamination level lower than **Class 9** of **NAS 1638** is recommended.



Failure to maintain the required filtration affects the manufacturer's warranty on the hydraulic motor.

4.2.5 Priming the hydraulic motor casing

The hydraulic motor casing must be filled after repairs or in the event of leaks.



It is IMPERATIVE that this operation be performed before start-up and after a repair job.

NOTICE	
	DANGER DUE TO INSUFFICIENT FLUID LEVEL The hydraulic motor may be damaged.
	▷ Check the oil level if the cutting unit is assembled.

- Ensure that the operator is equipped with the appropriate level of personal protective equipment when exposed to the oils used in the hydraulic system before performing this task.

4.2.6 Checking the oil level

- Make sure that the hydraulic oil cannot run out of the hydraulic motor. The filler opening must be at the top.
- Loosen the level check plug.
- When oil comes out of this hole, re-tighten the screw.



4.2.7 Topping up hydraulic oil

- Disconnect the leak-oil line at the reservoir end (before the filter). Loosen the level check plug. Fill the casing via this line until oil escapes from the hole of the level check plug.
- When oil comes out of this screw, re-tighten the screw (vent the engine).
- The motor casing capacity is about **2.0** litres (0.53 gallons).
- Reconnect the leak-oil line.

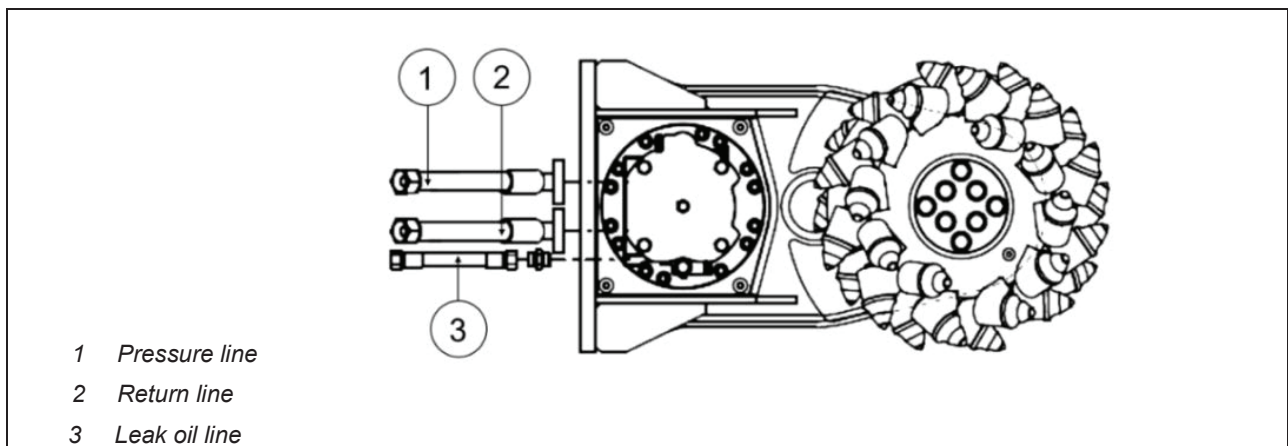

CAUTION



WARNING OF ENVIRONMENTALLY HAZARDOUS SUBSTANCES

Oil escapes from the level check plug.

- ▷ For storage, position the cutting unit as illustrated. For this purpose, the ventilation valve must be at the top.

4.3 Before initial start-up

Before initial start-up, the pre-shift maintenance schedule must be performed and torque settings checked.

- Do not allow the cutting unit to continue running at idle or under full load.
- Ensure that the hydraulic circuit complies with the relevant technical description for the machine.
- No load is to be placed on the gear as long as it is in the running-in period. Therefore, no cutting tasks should be performed before the operating temperature has been reached.
- During the running-in period, the hydraulic oil temperature should be checked, a value between **50°C** and **60°C (122°F and 140°F)** is acceptable. It should under no circumstances exceed **80°C (176°F)**.
If this happens, cooling must be improved or output reduced.
- After the initial operating period, the flow rates and pressures should be checked and reset if necessary.
- The pressure in the hydraulic motor casing is not to exceed **3 bar (43.5 psi)** (corresponds to the pressure in the leak-oil line).

4.4 Hydraulic transverse cutting units installation and commissioning report

Dealer:		Customer:		
Type of cutting unit:		Cutting unit identification no.:		
Type of hydraulic motor:: LD / MD / HD / XHD			
Putting into operation Place / Date:	Type of excavator / base vehicle:	
		Vehicle identity no.:	
Excavator drive power:kW	Oil flow hammer and cutting unit control circuit:l/min (g/min)	
Hydr. connection of cutting unit:	<ul style="list-style-type: none"> • Hammer control circuit • Grab control circuit • Other control circuits 	Secondary protection for hammer control circuit:bar (psi)	
Motor drain line: (pressureless in hydraulic oil tank)	Yes/No	Combination of return and drain oil lines: (following operat. instructions)	Yes/No (Only permissible in exceptional cases!)	
Pressure / flow adjustment for cutting unit control circuit:	Operating pressure	Hydraulic oil flow		
		100 bar (1450 psi)	 l/min (g/min)
		150 bar (2175 psi)	 l/min (g/min)
		200 bar (2900 psi)	 l/min (g/min)
		250 bar (3626 psi)	 l/min (g/min)
		300 bar (4351 psi)	 l/min (g/min)
		350 bar (5076 psi)	 l/min (g/min)
Back pressure in drain line (on cutting unit exit)bar (psi)		Back pressure in return line (on cutting unit exit)bar (psi)		
Underwater operation: Yes/No		If yes - gear box breather concealed: Yes/No		
Additional information: (range of application, geology etc.)		Verschiedenes:		
The receipt of the cutting unit in perfect condition, the receipt of the operating instructions as well as the instructions obtained for the proper operation and maintenance of the hydraulic cutting unit and correct hydraulic connections and adjustment of the base vehicle (excavator) is confirmed herewith.				
Place / Date:	Name / Signature (dealer customer service):	Name / Signature (customer):		
.....		
Note: In case of conversion / mounting of the cutting unit on a different excavator, a new report must be created!				

5 Operation

5.1 Description

The **Auger Torque** Hydraulic Transverse Cutting Unit ("TCU"; "cutting unit") is suitable for mounting on any type of hydraulic excavator provided the attachment carrier can supply the required power and machine stability is always ensured. It is mounted to the excavator dipperstick to replace the bucket, either through direct attachment or using a quick-attach system.

Their power makes **Auger Torque** cutting units flexible for a wide range of applications. The cutting units are designed to cut most types of rock, brickwork, concrete and asphalt etc. The **Auger Torque** cutting unit can run at full system pressure. This means there is no need to adjust the secondary pressure lower than the system pressure, thus avoiding overheating of the hydraulic circuit.

Although generally less noisy than other excavation methods the user must take into consideration the standards for noise protection during operation and carry out a noise measurement if required. Appropriate protective measures must be taken. In order to ensure functionality and the safe operation of the equipment, we recommend you handle it properly and regularly perform maintenance and inspection tasks. Improper handling will result not only in problems with the unit, but will also negatively affect operating performance.

The **WS60 Transverse Cutting Unit** is designed for excavators/attachment carriers with an operating weight between **18 t and 30 t**.

Your **Auger Torque** technical team can advise you on the most appropriate machine configuration and the ideal equipment for your project.

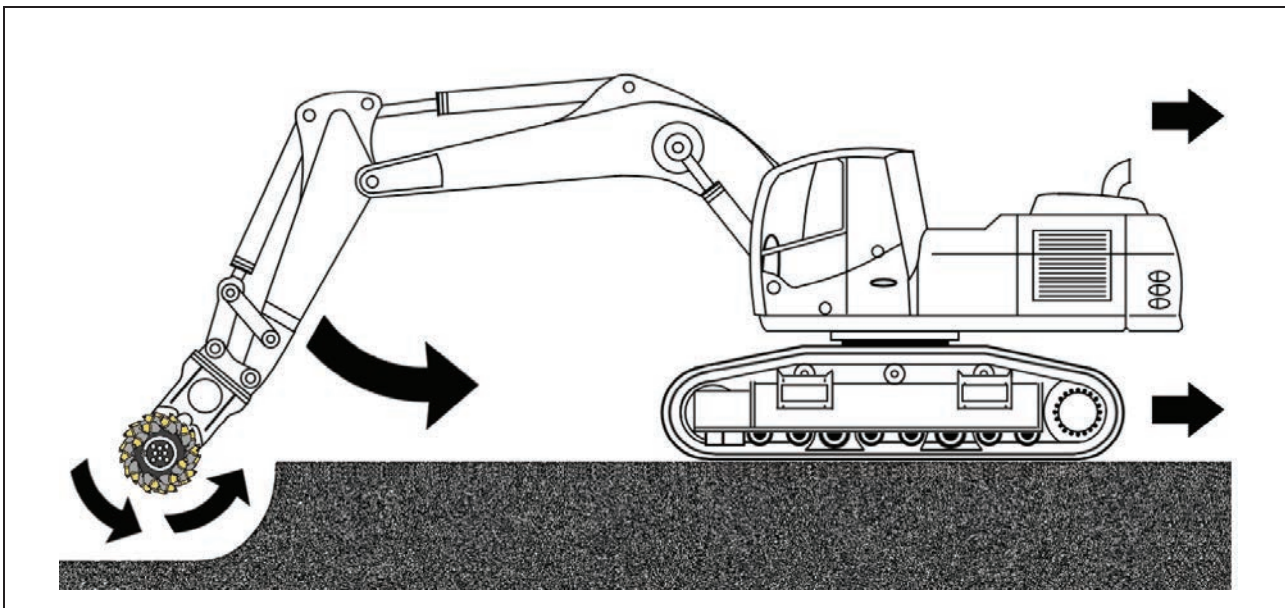

Cutting operations are best if the cutting unit drum moves into the direction of the attachment carrier. If the unit is moved sideways to achieve a larger cutting area, it must be ensured that the pressure on the excavator's boom, arm and cutting drum bearing is not too strong.

5.2 Examples of Using Cutting Unit

When using the Cutting Unit on vertical surfaces, such as walls, we recommend that the cutting unit is either turned around 180°.

This reduces vibrations and reaction forces while cutting and prevent the cutting unit from trying to climb the vertical surfaces.

5.2.1 Examples of Using Cutting Unit in Ditches

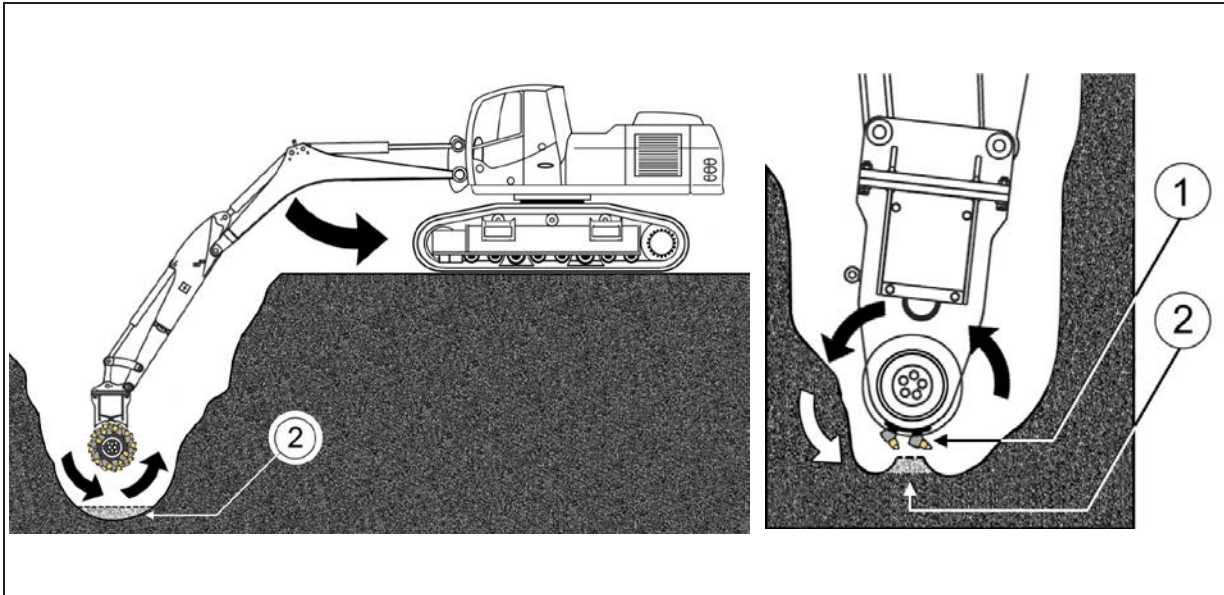

5.2.2 Examples of Using Cutting Unit with Asphalt

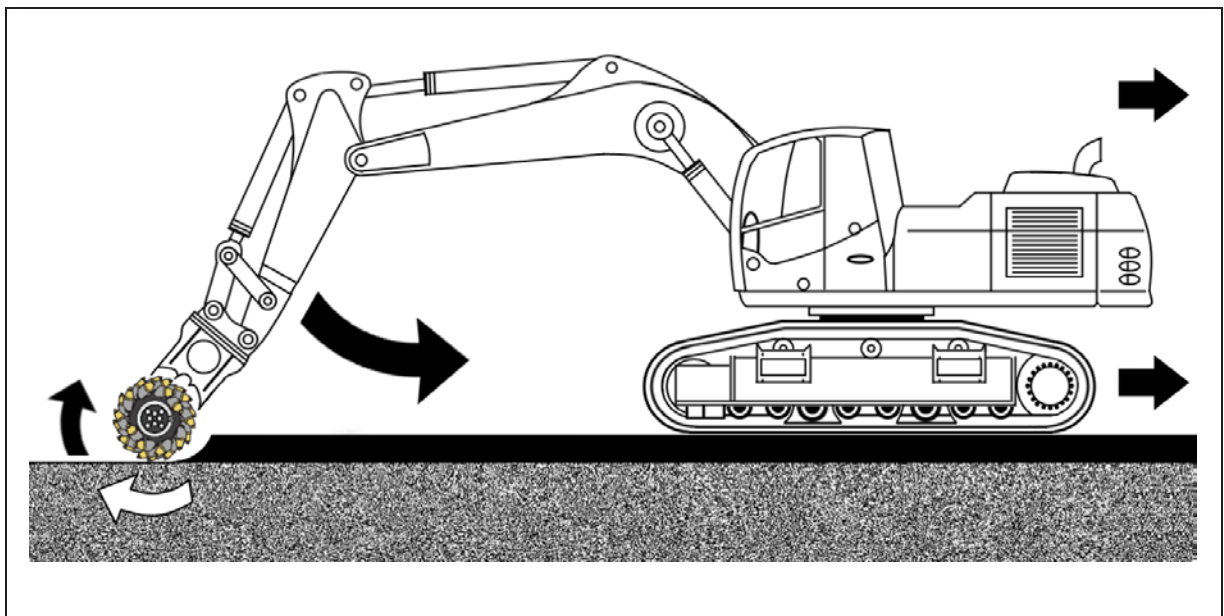

This arrangement prevents larger elements from breaking off in an uncontrolled manner.

5.2.3 Example of Using Cutting Unit on Walls

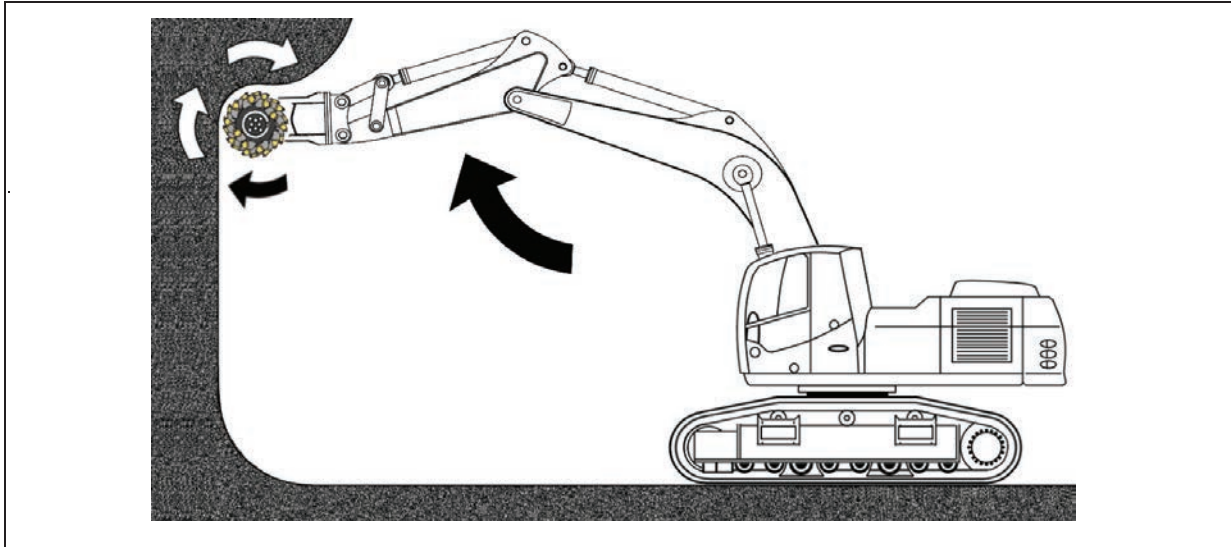

5.2.4 Operation under water

i Our Technical Service has to be consulted before the cutting unit is used in wet environments or under water up to a depth of 20 metres (65 ft) as the cutting unit has to be converted to this purpose.

Tripple greasing intervals of the labyrinth sealing system of the drums. (Use bio-degradable grease as water may flush out the grease)

- i** • Replace the air discharge plug by a stop plug (see spare part catalogue).
- Once the underwater operation is completed, re-install the air discharge plug.

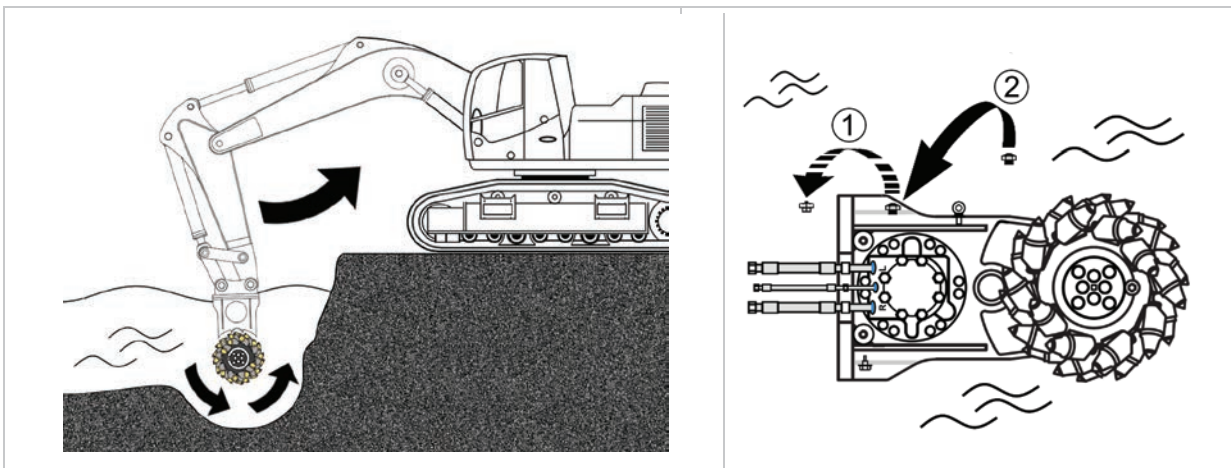

Pos.	Description
1	Air discharge plug
2	Stop plug

5.2.5 Trenching in narrow conditions

For trenching applications, the distance across the drums can be set to give the exact trench width. However, this will result in a central piece being left not excavated where there cannot be any teeth due to the nature of the twin drum arrangement. In this case, a central bracket is available with static teeth to break the remaining rock using the action of the excavator bucket ram. Please consult your responsible **Auger Torque** dealer if this is a requirement.

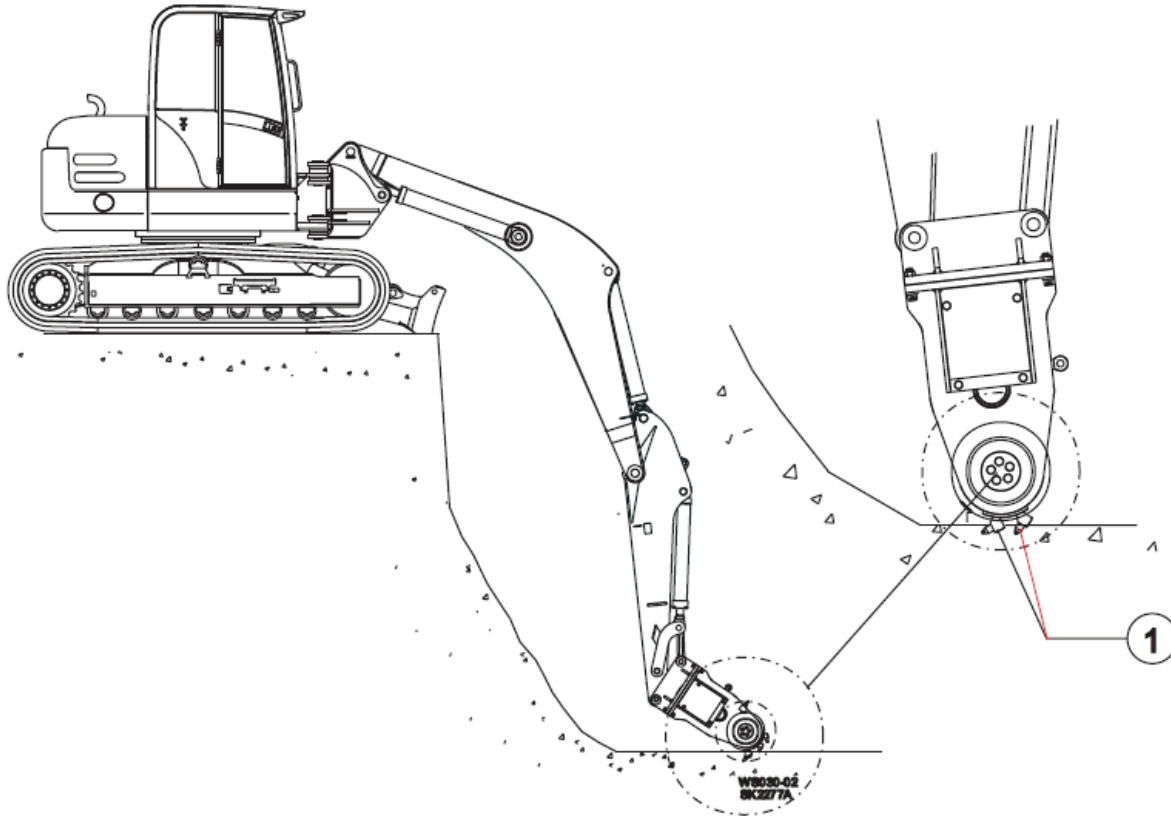

- *Central bracket with static teeth allowing central (uncut) area to be excavated*

5.3 Cutting drum selection

The selection of the cutting drum and tooth configuration depends on the application in question.

- **Excavating drums** are used for excavating soft to medium-hard rock with the teeth placed to give the most efficient cutting rates possible.
- **Profiling drums** are used for profiling, in other words whenever a precise or relatively smooth surface is required. These drums produce smaller pieces of rocks, so they are not an efficient means of excavation.
- Similar in design to rock drums, **demolition drums** feature an additional spiral serving as cutting depth limit. Demolition drums are used for the toughest cutting applications.

To optimise cutting/ excavating, different cutting drums and tooth configurations are available. Always consult your **Auger Torque** dealer.

For cutting drum dimensions see chapter **Cutting drums**.

5.3.1 Excavating drum

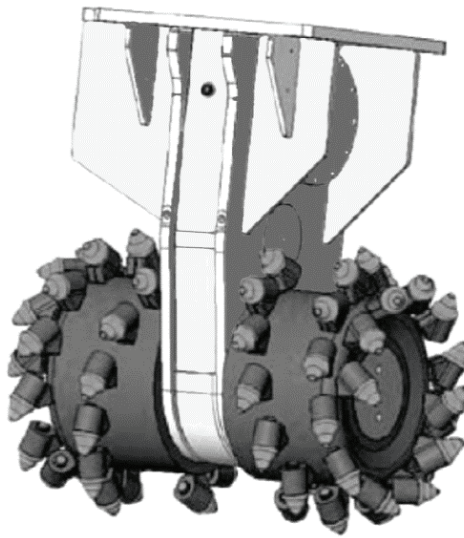

- For soft to medium-hard rock
- Teeth for maximum productivity and cutting performance
- No spiral blade to limit tooth penetration (tooth penetration limitation)

5.3.2 Profiling drum

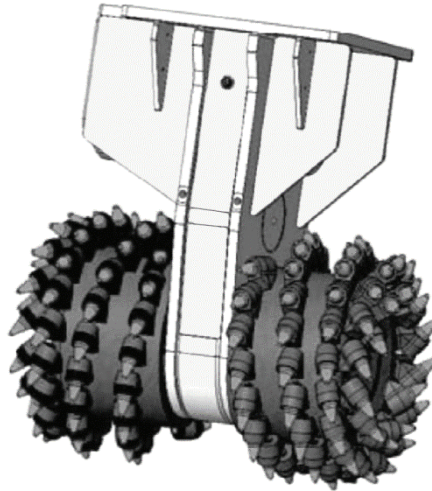

- For soft to medium-hard rock - whenever a precise or smooth surface is required.
- A higher number of teeth enables accurate surfaces and reduced vibration but lower cutting performance.

5.3.3 Demolition drum

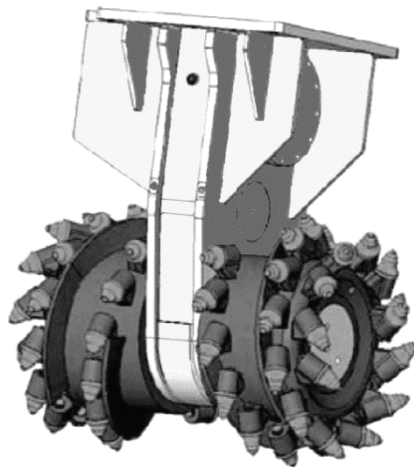

- For medium-hard to hard rock and concrete
- Wear-protected spiral blade for limited tooth penetration, lower vibration and smoother operation.

5.4 Examples tooth types

5.4.1 Standard tooth

For cutting soft to semi-hard stone, i.e. asphalt, salt, clay.

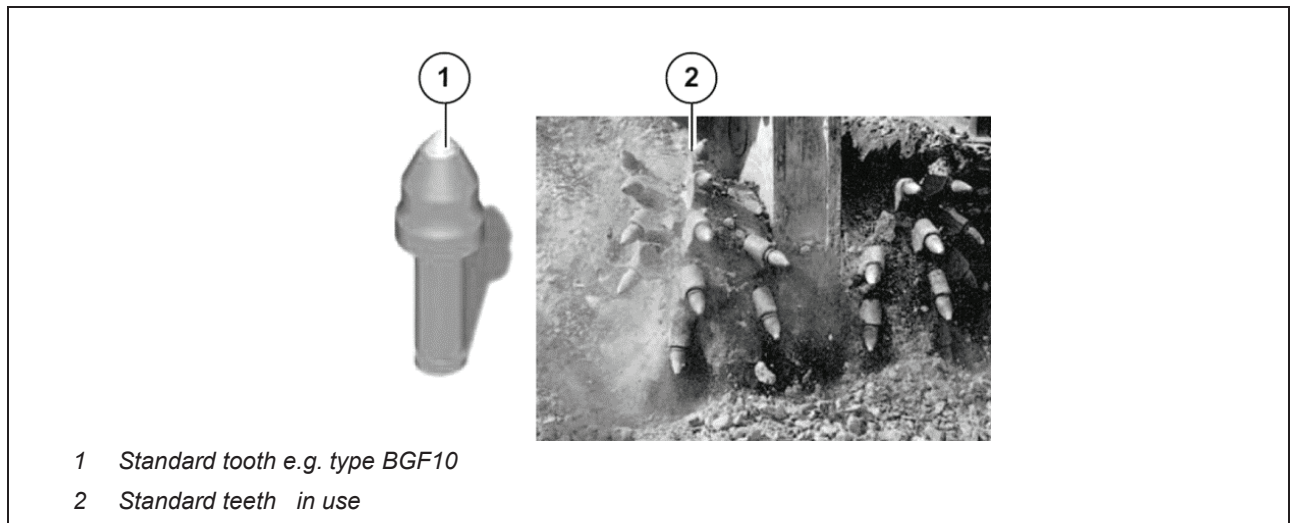

5.4.2 Heavy-duty tooth

For cutting semi-hard to very hard stone, i.e. limestone, concrete.

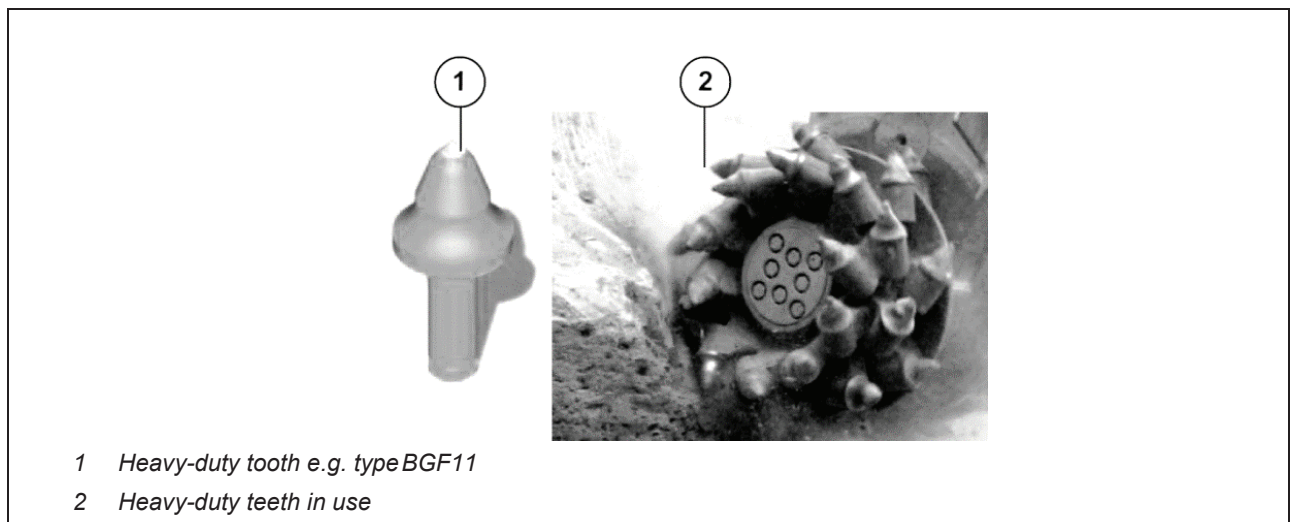

5.4.3 Wear-protected tooth

For cutting very abrasive material, i.e. sandstone, blast furnace gravel.

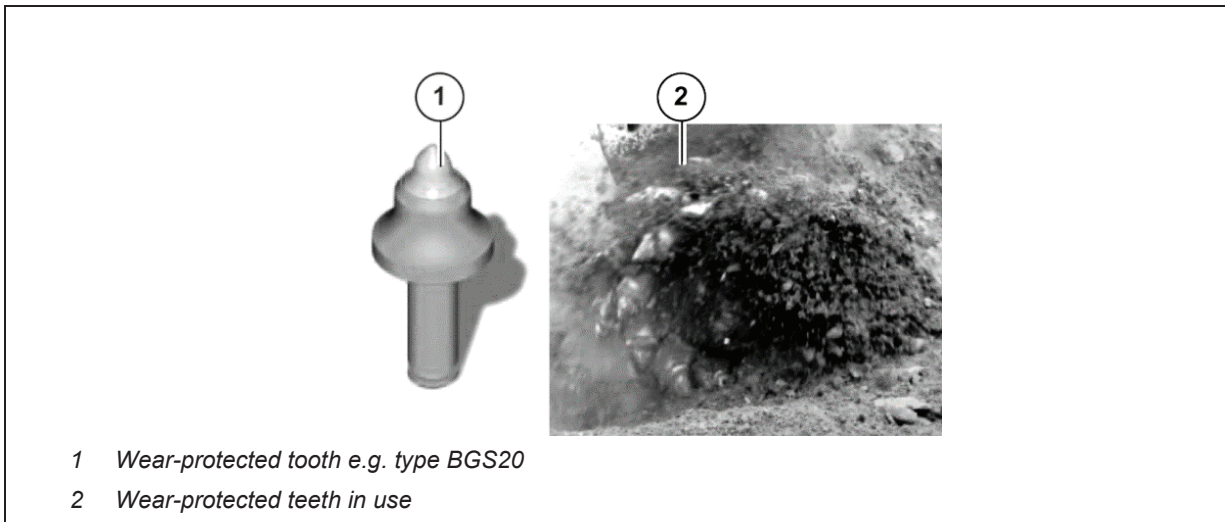

 Other teeth are available for special purposes and materials.

5.4.4 Wood-cutting tooth

For cutting tree stumps.

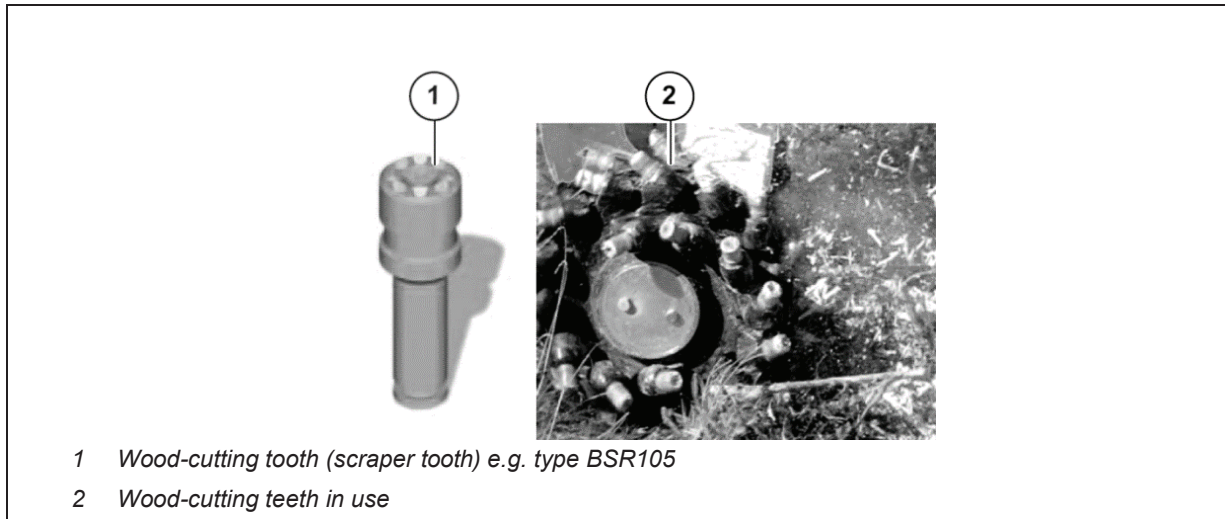

5.5 Regulations concerning environmental protection

Applicable environmental requirements must be observed for all tasks performed on and with the machine.

During installation, repair and maintenance tasks, particular care must be taken that substances that would damage the environment such as:

- lubricating greases and oils
- hydraulic oils
- fuels
- coolants
- cleaning fluids containing solvents

These substances must be collected, transported, kept and disposed of in suitable containers.

If the substances listed above do reach the soil, the leak or outlet must be stopped immediately and the fluid must be cleaned up with a suitable absorbent material.

If necessary, the soil involved must be removed.

Absorbent materials and removed soil must be disposed of properly.

Applicable environmental requirements must be observed.

6 Maintenance and Care

6.1 Maintenance plan

The maintenance intervals indicated are recommended values and must be adhered to. Local operating conditions may require shorter maintenance intervals.



The maintenance intervals are based on single-shift operation (8h/day, 20 days/month, 12 months/year).

In multiple-shift operation the maintenance intervals must be shortened accordingly.

CAUTION	
	<p>DANGER DUE TO ENVIRONMENTALLY HAZARDOUS SUBSTANCES Escaping oil may pollute the environment.</p> <ul style="list-style-type: none"> ▷ Wear protective clothing when dealing with oil. ▷ Collect the waste oil and dispose of according to regulations.

Maintenance interval for single-shift operation	Activity	To be performed by
Daily before start-up	<ul style="list-style-type: none"> • Check the correct installation of the cutting unit on the adapter bracket and on the attachment carrier, (see Chapter Screwed connections – tightening torques) • Check for leaks on the gearbox. • Check the gearbox oil level. • Check for leaks on the hydraulic motor. • Check for leaks and damage on the hoses. • Ensure the gearbox breather is clear. • Check all teeth and tooth boxes for wear. Replace worn teeth immediately. • Grease the cutting drum sealings. 	Operating personnel
Daily after work	<ul style="list-style-type: none"> • Clean the cutting unit thoroughly. • Check that all teeth are free moving. 	Operating personnel
Every 100 hours / 2 weeks	<ul style="list-style-type: none"> • Check the condition of the hydraulic motor. • Clean the magnetic plug. • Check the tightening torques (see Chapter Screwed connections – tightening torques). 	Operating personnel
Every 500 hours / once yearly	<ul style="list-style-type: none"> • Replace transmission oil. • Check the tightening torques (see Chapter Screwed connections – tightening torques). 	Service Personnel
Temporary shutdown	<ul style="list-style-type: none"> • Clean the cutting unit thoroughly. Keep it in storage, in a dry place. If necessary, dismantle the teeth due to danger of corrosion. • Ensure that hydraulic oil cannot escape from the hydraulic motor after dismantling the cutting unit from the hydraulic motor after dismantling the cutting unit from the excavator. Gearbox breather on top. 	Operating personnel

6.2 Gearbox oil level

Fill the gearbox using the filling hole.
Position the gearbox as shown in the Figure.

- The gearbox capacity is approximately **23 litres (6 gallons)**.

NOTICE	
	<p>DANGER DUE TO INSUFFICIENT FLUID LEVEL The gearbox may be damaged; warranty expires.</p>
	<p>▷ Check the oil level regularly.</p>

Ölspezifikation

A heavy-duty industrial gear oil on mineral oil basis (**SAE 105 Grade**) complying with the minimum requirements for **CLP** lubricating oils according to **DIN 51517-3** and **CKD** lubricating oils according to **ISO 12925-1** should be used.

BP	ESSO	CASTROL	MOBIL
GRXP 320	SPARTA N EP320	ALPHAS P 320	MOBIL GEAR SHC 320
SHELL	TEXACO	TOTAL	FUCHS
SHELL Omala Oil 320	MEROPA 320	TRANS-GATE	POWER GEAR

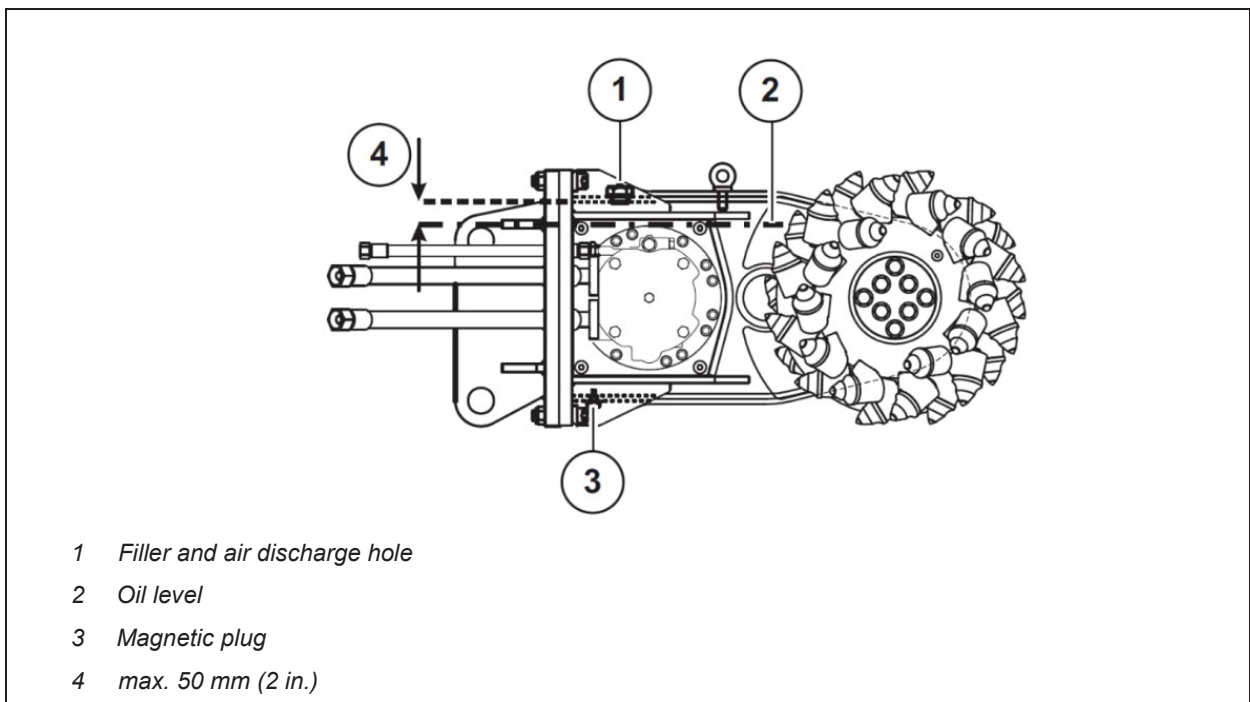

6.3 Lubrication



Lubrication prevents contamination or demolition material from penetrating the housing sealing system and thereby prevents damage.

- Lubricate labyrinth seal of the cutting drum via lubrication nipple until grease escapes on the interior drum side

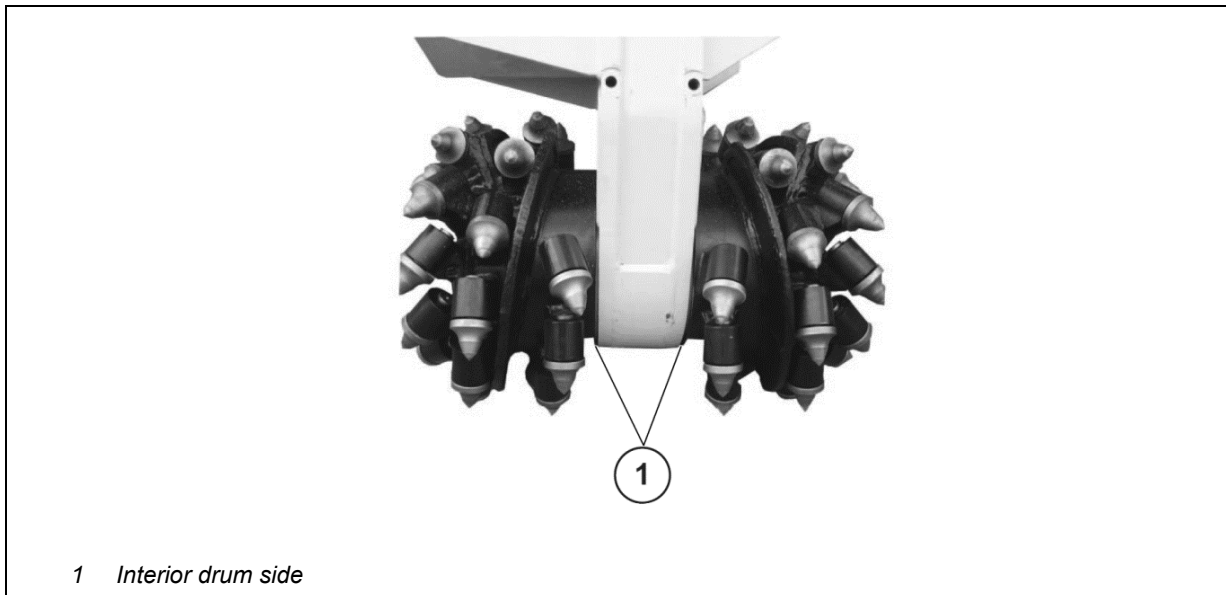

6.3.1 Grease nipple

The cutting drums have a grease nipple on the face from where the lubrication is pressed into the Labyrinth seal system

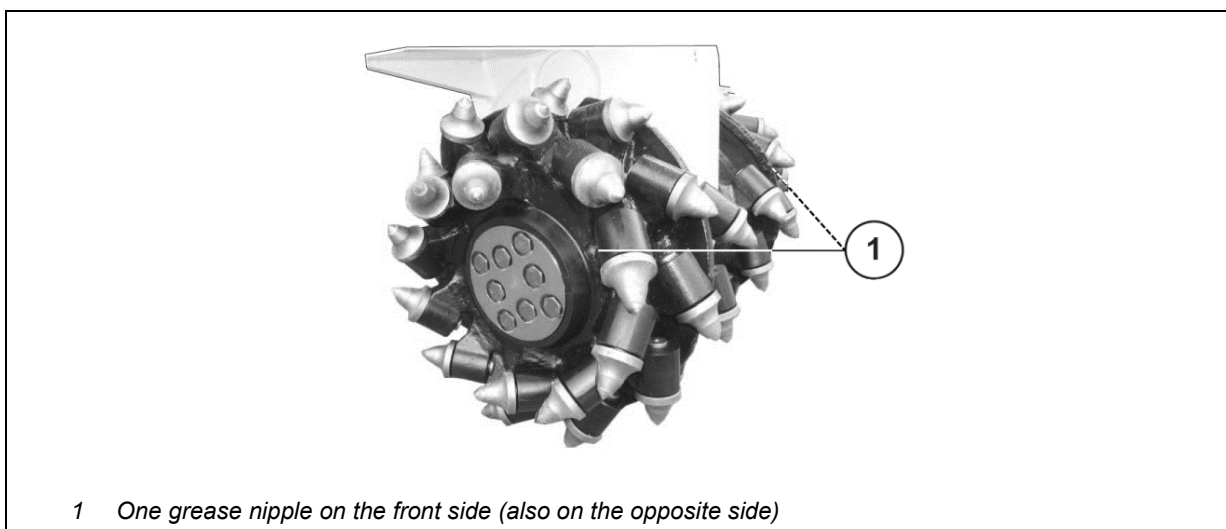

6.4 Screwed connections – tightening torques



Replace the nuts and bolts with new ones after dismantling. Use “medium strength threadlocker” to glue the bolts. At the check marks in the table below, use of threadlocker is mandatory. At all other bolted connections, its use is recommended for additional safety.

Pos.	Description	Maintenance intervals [h]	Dimension	Tightening torque Nm (ft-lb)	Thread-locker	Number
1	Hydraulic motor to casing	100	M16x90-12.9	370 (273)	✓	14
2	Motor cover	100	M16x40-10.9	100 (74)	✓	8
3	Cover	100	M12x50-10.9	120 (89)	-	12
4	Fastening to attachment carrier	daily	M24x110-10.9	930 (686)	-	10
5	Casing cover	500	M8x25-8.8	25 (18)	-	10
6	Dust cover / Drum attachment	100	M20x60-10.9	540 (398)	-	8 (per side)
7	Seal carrier on output shaft	500	M10x35-8.8	46 (34)	✓	6 (per side)
8	Seal carrier on drive shaft	500	M10x12-8.8	46 (34)	✓	6 (per side)
9	Seal carrier to casing	500	M12x50-10.9	120 (89)	-	12 (per side)
10	Dust cover	100	M16x25-8.8	195 (144)	-	4
11	Venting valve	100	¾ UNF	58 (43)	-	3

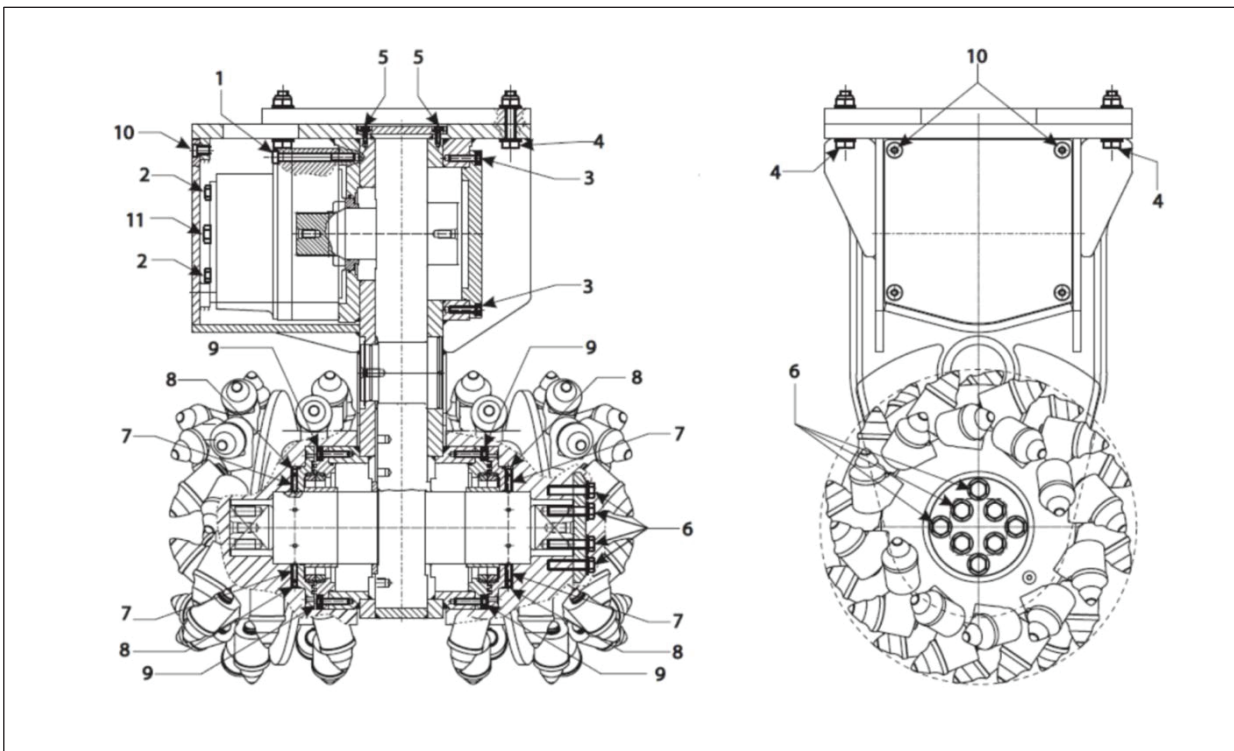

6.5 Checking the condition of the hydraulic motor

NOTICE	
	MATERIAL DAMAGE ON HYDRAULIC MOTOR Damage of hydraulic motor
	▷ Have repairs carried out by trained service personnel.

The following procedure is only to be carried out by a responsible person familiar with the functional principle of hydraulic systems.

- Switch off the engine of the attachment carrier.
- Ensure the hydraulic oil is not too hot.
- Disconnect the drain-oil line hose from the attachment carrier.
- Place the end of the hose coming from the hydraulic motor into a receptacle of known capacity.



If there is tank pressurisation in the attachment carrier, oil may escape before implementing. Make sure the tank is vented.

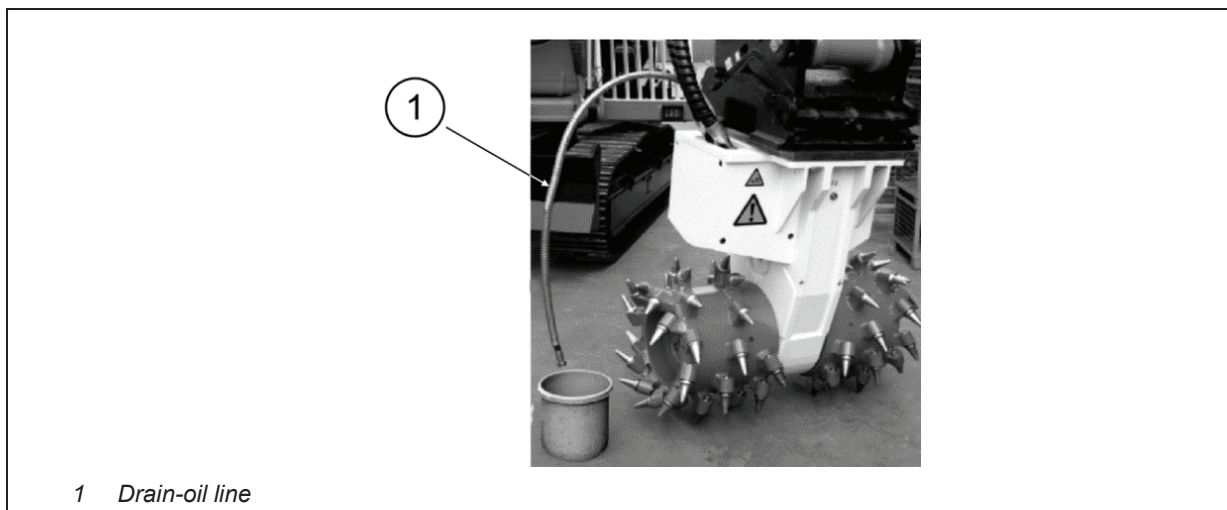

- Start the engine and keep it running at low speed.
- Observe the amount of oil flowing from the hose - it must not be more than **2.0 l/min (0.53 g/min.)**.
- If the oil flow is less than **2.0 l/min (0.53 g/min.)**, increase the motor speed up to full speed noting any increase in oil flow.
- At full speed the oil flow must be no more than **4.0 l/min (1.06 g/min)**.



If more oil flows, the motor must be inspected, and, if needed, replaced.



A precise examination of the engine is made by the manufacturer.

6.6 Replacing the teeth on the cutting drums

Please read through the following instructions carefully. Failure to observe them may void the warranty. If you are in doubt, contact your responsible dealer.

NOTICE	
	MATERIAL DAMAGE OF THE CUTTING UNIT Have repairs carried out by -trained service personnel.
	▷ Have repairs carried out by -trained service personnel.

- Clean the cutting unit and the jobsite thoroughly.

WARNING	
	DANGER OF CRUSHING Danger of crushing due to cutting unit
	▷ Secure the cutting unit against slipping and toppling down.

- Set down the cutting unit in a position that will allow the cutting drums to rotate freely.
- Switch off the engine of the attachment carrier.

WARNING	
	DANGER CAUSED BY PARTS FLYING AROUND Parts flying around during repair work can cause severe eye injury or the loss of eyesight
	▷ Use goggles or another kind of eye protection.

6.6.1 Tools for removal and installation of teeth

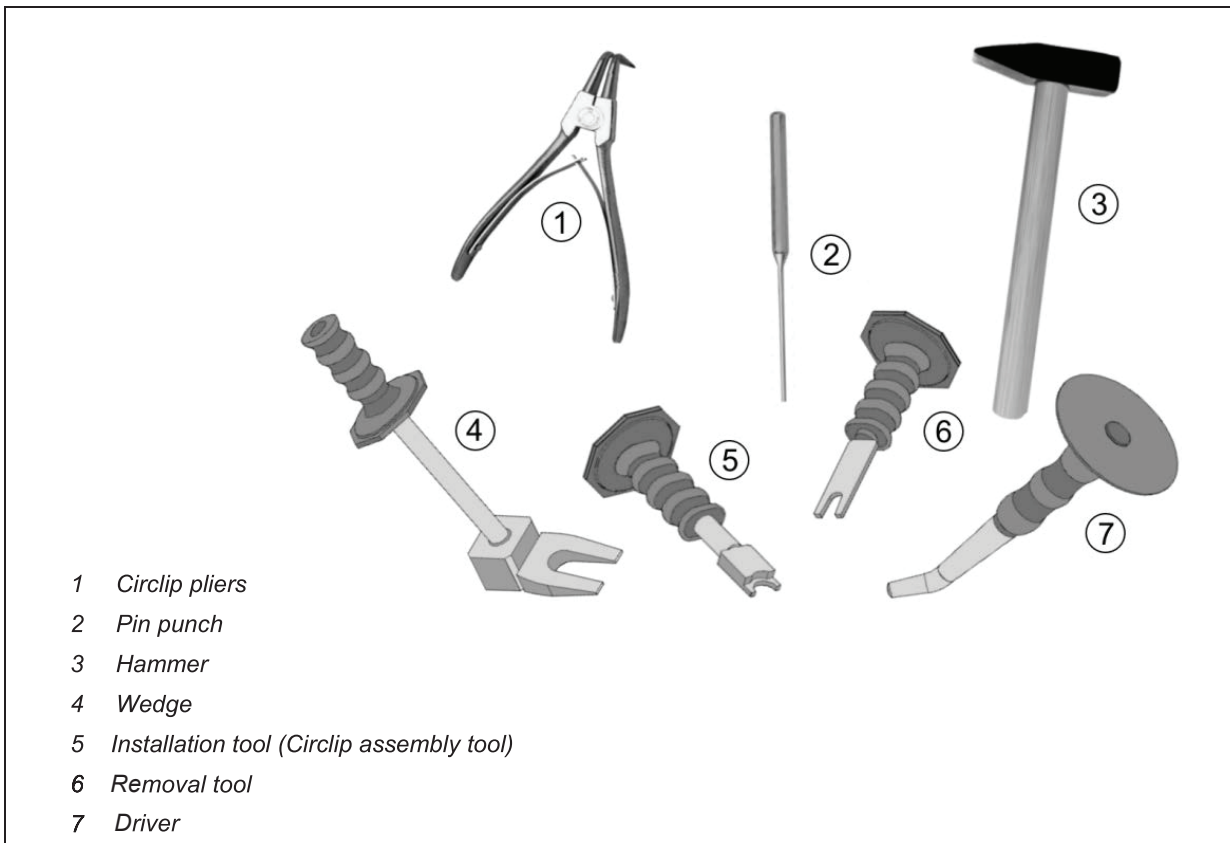

6.6.2 Cutting unit setting down

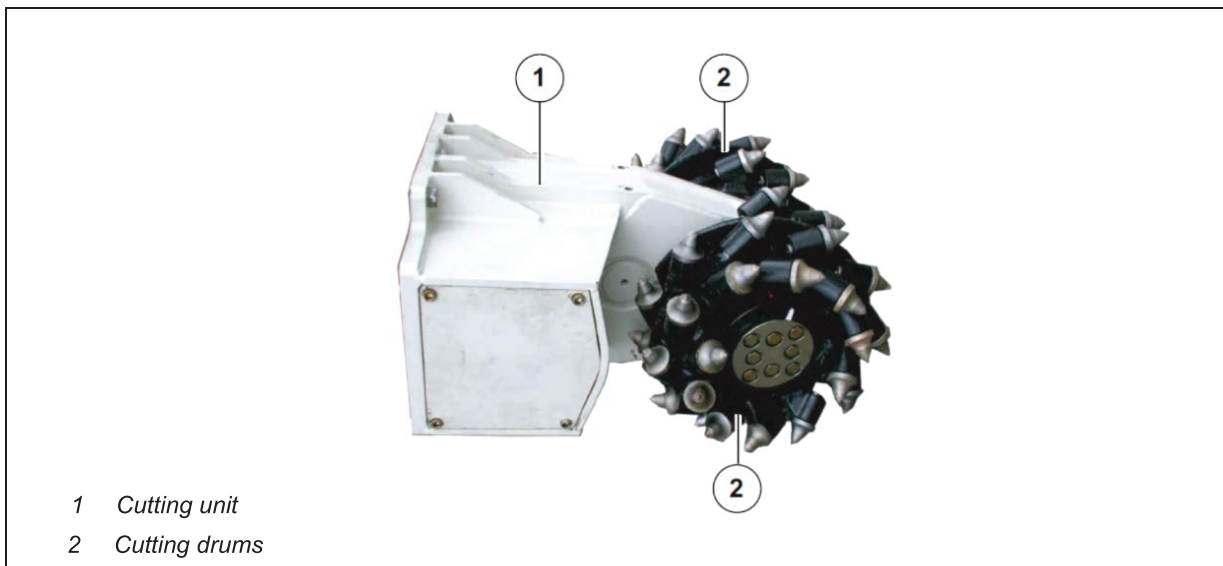

6.6.3 Removing circlip or C-clipping and teeth

- Use a **circlip pliers** to remove the **circlip** or a **hammer** and the **removal tool** to remove the **C-clipping** from the tooth holder.

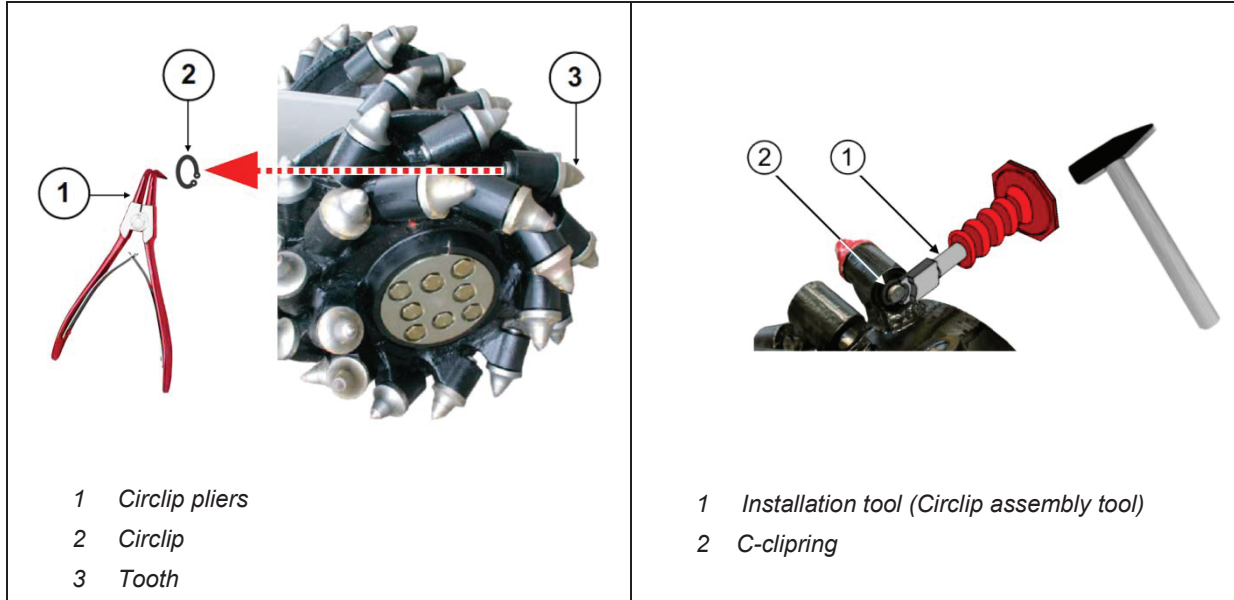

- Using a **hammer** and the **driver** or the **pin punch** and knock out the tooth from the tooth holder.

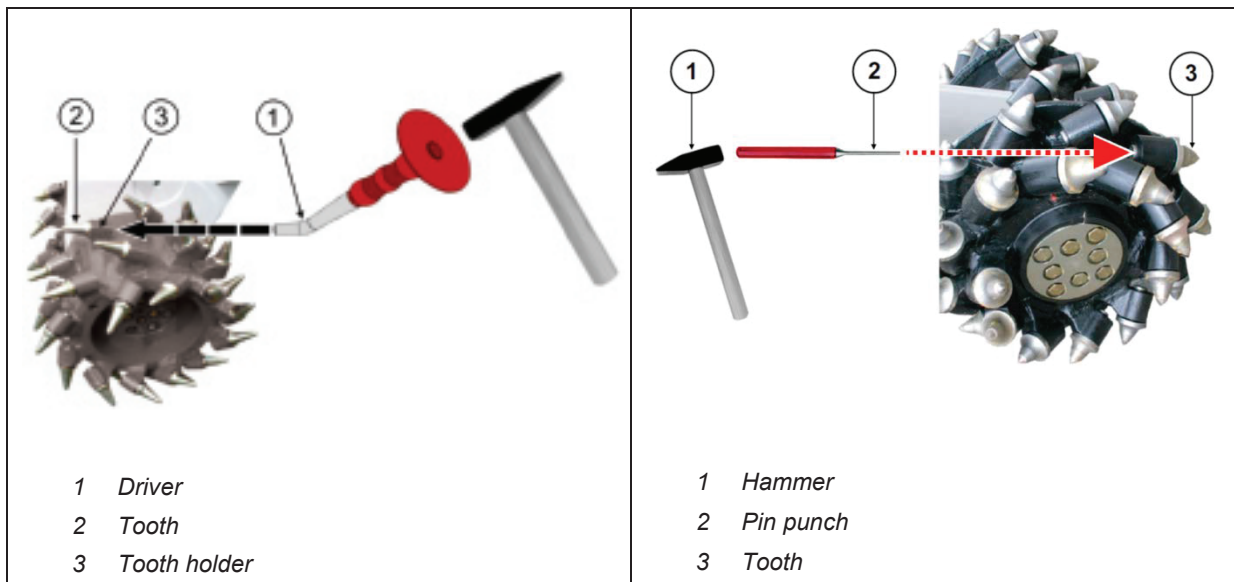

- Loosen the tight tooth with the **wedge** by knocking the wedge with a hammer between the tooth and tooth holder.
- Remove any other teeth with the same procedure.

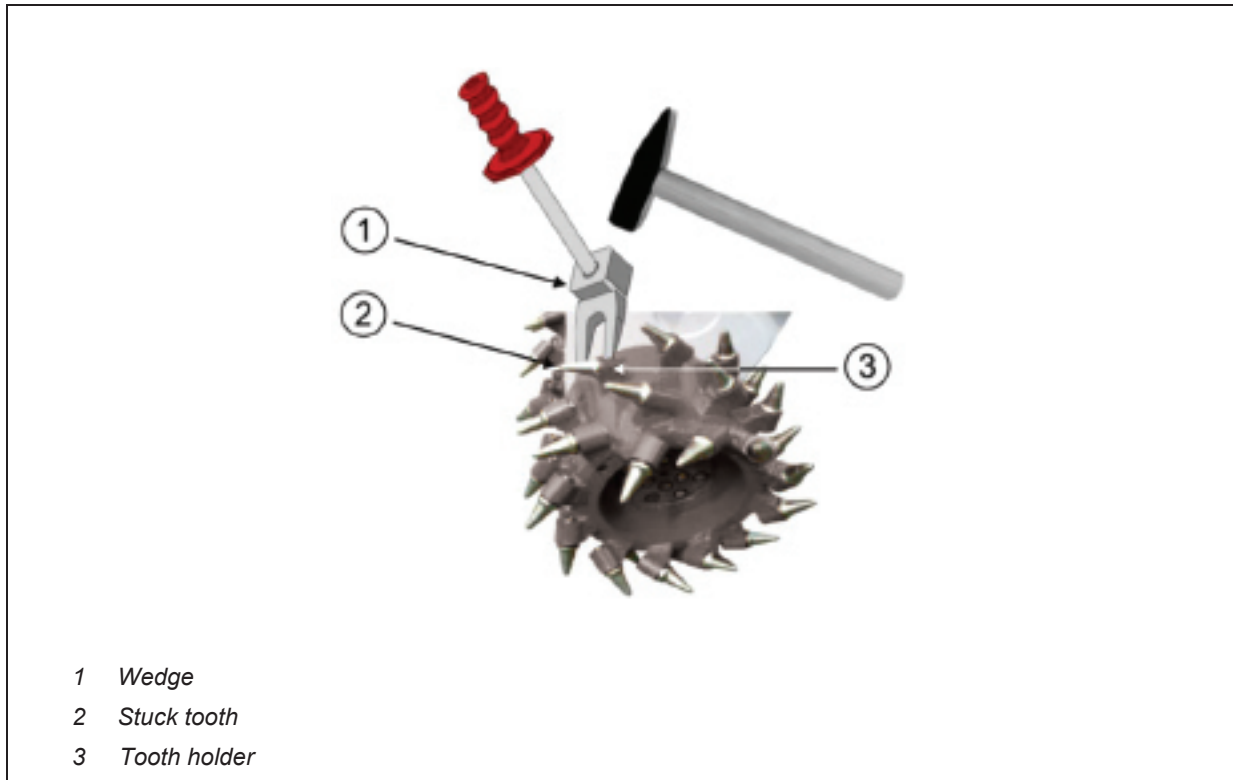

6.6.4 Installing teeth and insert circlip or C-clipping



Clean the tooth shank before installation of used teeth.



Install teeth without any lubrication (no grease or oil).

- Push the tooth into the tooth holder of the cutting drum.
- Use the **circlip pliers** to insert the **circlip** in the groove of the tooth holder, or
- Place the **C-clipping** in the tooth slot and insert the C-clipping with the **Installation tool** (circlip assembly tool) into the tooth slot by knocking the Installation tool with a hammer until firmly seated.
- Insert any other teeth with the same procedure.

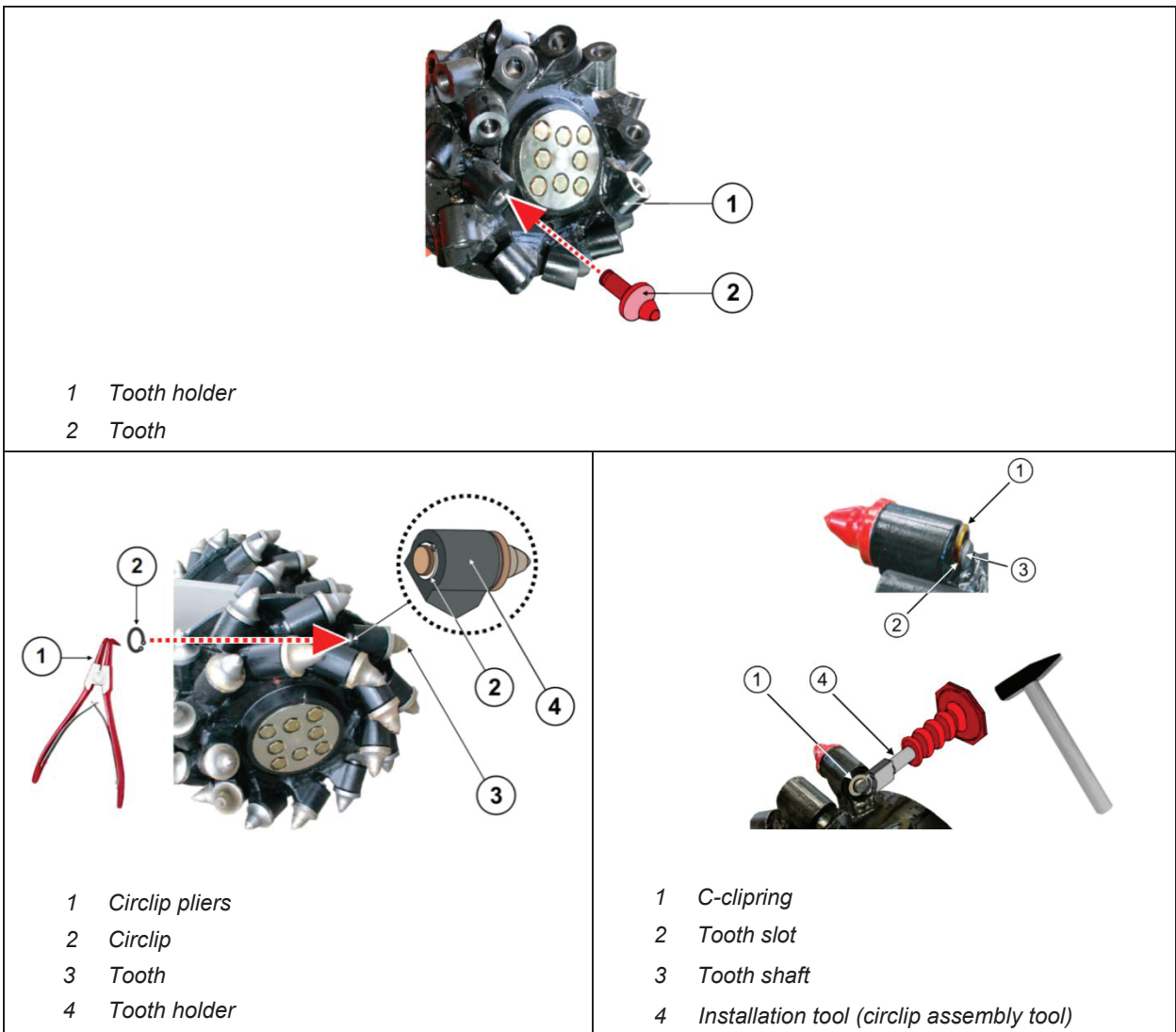

Before carrying out cutting operations, ensure that all teeth and circlips are correctly seated. It must be possible for the teeth to rotate freely in the tooth holder.

7 Transport

7.1 Delivery

The delivery is thoroughly checked and packed before shipment, however, damage caused by transport cannot be ruled out.

- Check against the packing list for completeness.
- Check the delivery for damage (visual inspection).
- If the delivery was damaged in transport:
Contact the forwarding agent immediately.

7.2 Packing

The cutter heads are attached to a metal transportation stillage and protected with plastic film.

Secure the cutter head

- Make sure the cutter head is set down so that the vent plug (1) is at the top.
- Make sure that no hydraulic oil leaks out of the hydraulic motor.
- Lash the cutter head down tightly with tension straps.

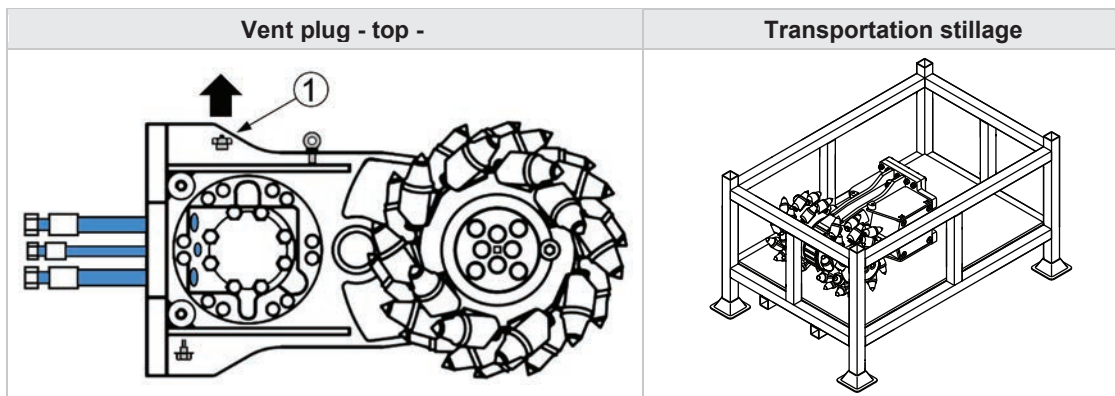

7.3 Transport of the packed cutting unit

The packed cutting unit is to be transported by forklift truck.

WARNING	
	DANGER DUE TO SUSPENDED LOADS If the cutting unit falls down, it may cause serious injury.
	<ul style="list-style-type: none">▷ Ensure sufficient load bearing capacity of the forklift truck. Weight of the cutting unit: 1,350 kg (2,976 lb).▷ The operator must be authorized to drive the forklift truck.

- Drive the forks of the forklift to the underside of the metal stillage (1).
- For unloading and transporting, the position of the centre of gravity must be determined by technically instructed safety personnel.
- Lift the box by max. **10 cm (3.94 in.)** and check the stability.
- Transport the stillage slowly and carefully to the installation place.
- Lower the stillage carefully and evenly.

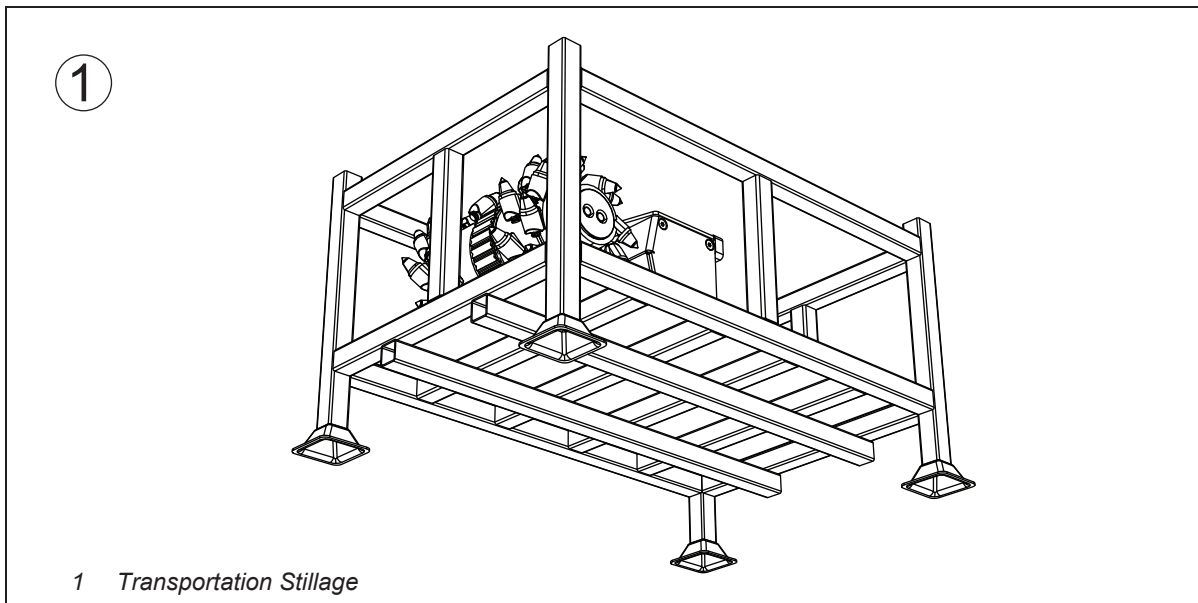

7.4 Transport of the unpacked cutting unit

7.4.1 Transport by crane

WARNING	
	DANGER DUE TO SUSPENDED LOADS If the cutting unit falls down, it may cause serious injury.
	<ul style="list-style-type: none">▷ An M20 DIN 580 ring screw should be used for lifting the transverse cutting unit with a crane.▷ Use adequate lifting gear; weight of cutting unit: 1.350 kg (2,976 lb).▷ The operator must be authorized to operate the lifting gear.▷ Observe the accident-prevention regulations.

- Make sure that the hydraulic oil cannot run out of the hydraulic motor. The venting plug must be at the top.
- Screw the ring bolt completely into the cutting unit.
- Attach the lifting gear.
- Carefully lift the cutting unit.
- Transport the cutting unit carefully and slowly.
- Lower the cutting unit carefully and evenly to the ground.

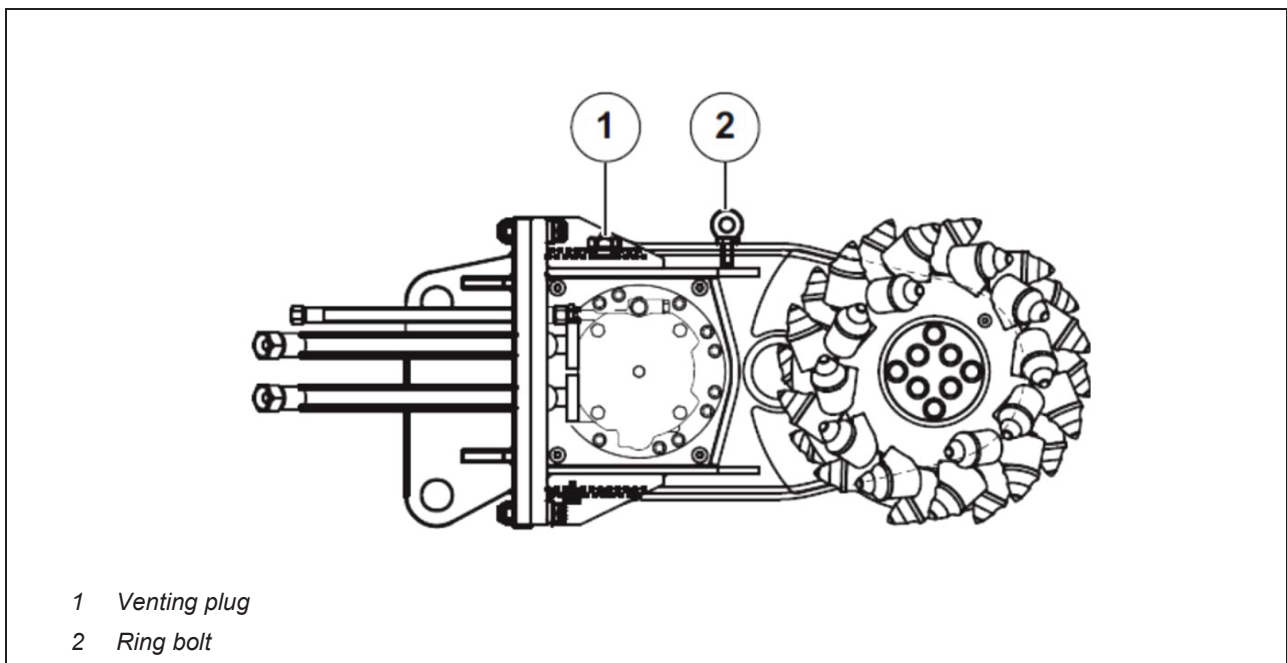

8 Technical data

The hydraulic cutting unit **KDC30** made by **Auger Torque** can be supplied with **excavating, profiling** or **demolition drums**. (If different teeth are required, contact your responsible **Auger Torque** dealer). Different motor displacements are available for different pump capacities.

8.1 KDC30-HD specifications (high displacement – 1884 cm³ (742 in³))

Nominal output	60 kW
Max. power peak	70 kW
Required flow rate	min. 140 l/min (37 g/min) to max. 210 l/min (55 g/min)
Recommended flow rate	180 l/min (47 g/min)
Max. pressure	350 bar (5076 psi) see output graph
Gearbox ratio	1.3
Output shaft torque	13.7 kNm (10,104 ft-lb) at 350 bar (5076 psi)
Output shaft speed	86 rpm at 210 l/min (55 g/min)
Tooth speed	2.8 m/s (9.2 f/s) at 210 l/min (55 g/min)
Tooth force	44.4 kN (32,747 ft-lb at 350 bar (5076 psi)
Weight (without adapter)	1,350 kg (2,976 lb)



Observe that the cutting unit must never be operated at maximum pressure and maximum flow rate at the same time as this would exceed the admissible nominal output. The cutting unit is to be used in the nominal output range. Pay attention to the output graph. If in doubt, contact our Technical Sales.

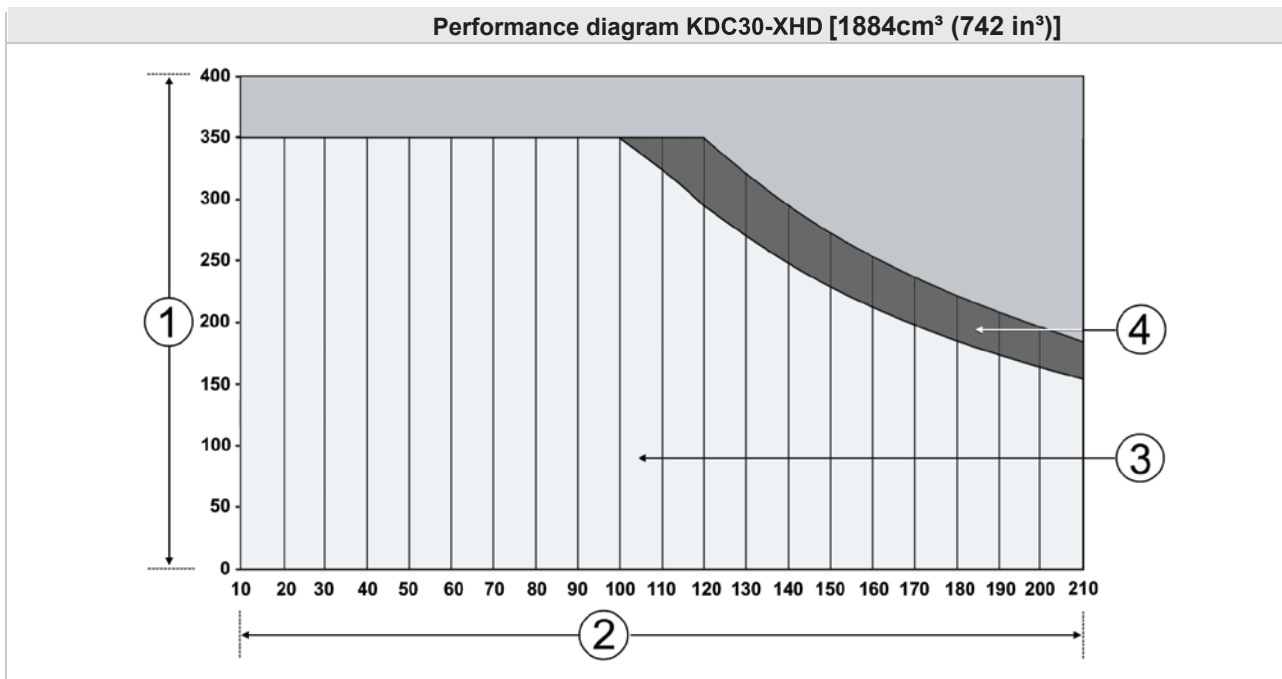

Pos.	Description
1	Operating pressure [bar]
2	Flow rate [l/min.]
3	Nominal rate
4	Power output [max.]

8.2 KDC30-MD specifications (high displacement – 1666 cm³ (656 in³))

Nominal output	60 kW
Max. power peak	70 kW
Required flow rate	min. 120 l/min (31 g/min) to max. 200 l/min (53 g/min)
Recommended flow rate	160 l/min (42 g/min)
Max. pressure	350 bar (5,076 psi) see output graph
Gearbox ratio	1.3
Output shaft torque	12.1 kNm (8,925 ft-lb) at 350 bar (5,076 psi)
Output shaft speed	92 rpm at 200 l/min (53 g/min)
Tooth speed	3.0 m/s (9.8 f/s) at 200 l/min (53 g/min)
Tooth force	39.3 kN (28,986 ft-lb at 350 bar (5,076 psi)
Weight (without adapter)	1,350 kg (2,976 lb)



Observe that the cutting unit must never be operated at maximum pressure and maximum flow rate at the same time as this would exceed the admissible nominal output. The cutting unit is to be used in the nominal output range. Pay attention to the output graph.

If in doubt, contact our Technical Sales.

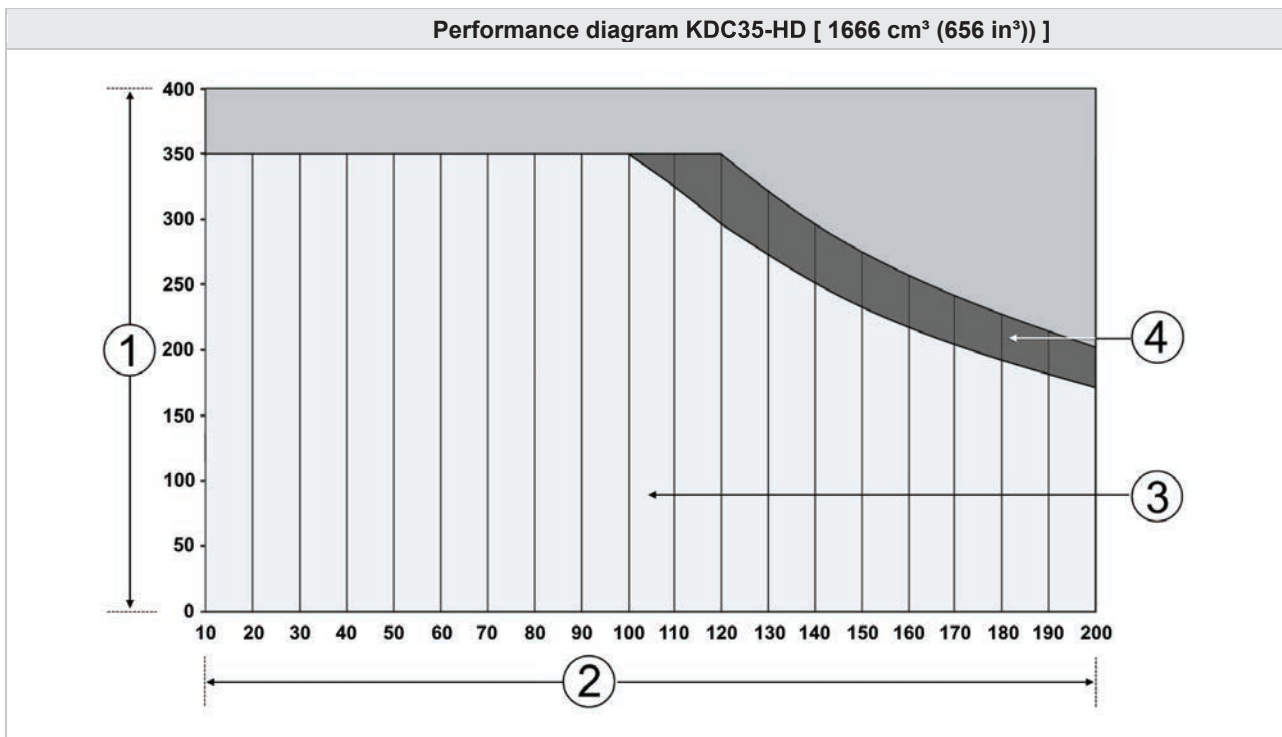

Pos.	Description
1	Operating pressure [bar]
2	Flow rate [l/min.]
3	Nominal rate
4	Power output [max.]

8.3 Cutting drums

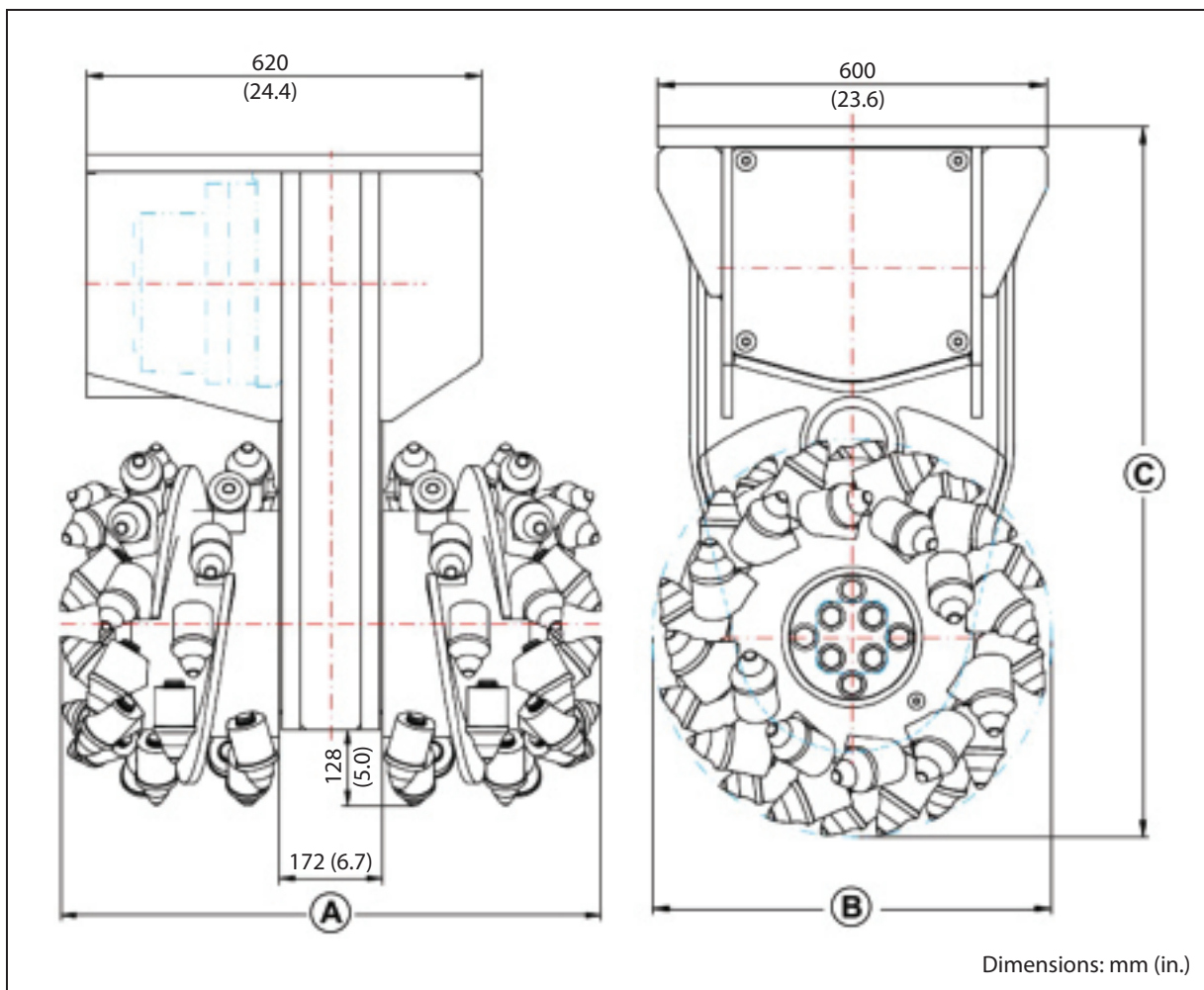

Drum type	Width of drum A mm (in.)	Drum diameter B Ø mm (in.)	Mounting height C mm (in.)
Excavating drum	900 (35.4)	615 (24.2)	1095 (43.1)
Profiling Drum	900 (35.4)	615 (24.2)	1095 (43.1)
Demolition drum	900 (35.4)	615 (24.2)	1095 (43.1)

9 Trouble-shooting

Malfunction	Measure	To be performed by
Cutting performance deteriorates	<ul style="list-style-type: none"> • Check all teeth and tooth boxes for damage and wear. • Check the hydraulic motor (see Maintenance chapter: Checking the condition of the hydraulic motor). 	Operating personnel
Cutting performance deteriorates	<ul style="list-style-type: none"> • Ensure that excavator hydraulic circuit is working correctly. 	Service Personnel
Cutting drums stop turning	<ul style="list-style-type: none"> • Check the correct connection of quick couplings. • Check if anything is trapped around the cutting drums and is blocking them. • With the excavator switched off, disconnect the hydraulic hoses and see if the cutting drums will turn by hand. 	Operating personnel
Cutting drums stop turning	<ul style="list-style-type: none"> • Ensure the excavator hydraulic circuit is working correctly. • If the cutting drums will not turn, remove the hydraulic motor (see Service Manual, Removing the hydraulic motor). If the cutting drums now turn, then the hydraulic motor is damaged and should be replaced. • If the cutting drums still do not turn, once the hydraulic motor has been removed, remove the cutting drums (see Service Manual, Removing the cutting drums) to see if anything is trapped inside the drums. 	Service Personnel
Gearbox oil leaks on the cutting drums	<ul style="list-style-type: none"> • If oil leaks from the cutting drums, the cutting drum seals are damaged and must be replaced (see Service Manual, Replacing the cutting drum seals and O-rings). 	Service Personnel
Hydraulic oil is leaking out of the gearbox breather	<ul style="list-style-type: none"> • The gearbox breather will leak a small amount of oil as the gearbox oil temperature increases. If a steady stream of oil leaks from the breather then the hydraulic motor to gearbox seal is damaged and must be replaced (see Service Manual, Changing the hydraulic motor and the gearbox seal and the O-ring between the seal carrier and the gearbox). In this case, the gear oil must be replaced after the repair is finished. 	Service Personnel

Malfunction	Measure	To be performed by
Hydraulic oil is leaking from the area of the hydraulic motor	<ul style="list-style-type: none"> • Check if the hose fittings are tight. • Check if the screws on the hydraulic motor are securely fastened. 	Operating Personnel
Hydraulic oil is leaking from the area of the hydraulic motor	<ul style="list-style-type: none"> • If oil is leaking from the bottom of the hydraulic motor, then the hydraulic motor to gearbox casing O-ring seal is damaged and must be replaced (see Service Manual, Changing the O-ring between the hydraulic motor and the casing). • If oil is leaking from the upper area of the hydraulic motor, then the O-ring between the motor cover and the hydraulic motor is damaged and must be replaced (see Maintenance, Replacing the O-ring of the motor cover). <p><i>A leak in this spot can be caused by a damaged motor cover. If there is excessive pressure from the casing, the plate may be bowed as a result. If this is the case, the condition of the motor leak-oil line and the hydraulic circuit should be checked to make sure that the motor has been correctly installed (see Installation of hydraulic connection).</i></p>	Service Personnel
Hydraulic motor rattling	<ul style="list-style-type: none"> • If there is a rattling noise from the hydraulic motor, there is insufficient pressure difference between the hydraulic motor return line and the hydraulic motor leak-oil line. This must be rectified (see Service Manual, Installation, Hydraulic circuit). 	Service Personnel
Damage / wear on the tooth boxes	<ul style="list-style-type: none"> • Wear on the tooth box increases if worn teeth are not replaced. You should therefore check the teeth regularly. 	Operating Personnel

10. Warranty Statement

All Drum Cutter products are warranted to be free from defects in materials or workmanship for the periods summarised below:

- Gearbox - 18 Months
- Hydraulic Motor - 18 Months
- All Other Parts / Products (excluding wear parts) - 12 Months

The warranty periods will commence from Date of Sale by an authorised Auger Torque Dealer. Evidence of the date of sale may be required and for Gearbox and Hydraulic Motor warranties to be valid the product must be registered with Auger Torque within 4 weeks of the date of sale. Extended Warranty (>12 months) Products can be registered by returning the Registration Card or completing the form on page 7. This warranty is not transferable beyond the initial purchaser of the product.

A warranty claim should be reported to the Auger Torque Dealer who supplied the unit. The Dealer, with the technical backup of Auger Torque, will make an initial assessment.

The customer is responsible for returning the product for warranty inspection to the original supplying dealer's facility. Parts should not be delivered without the prior agreement of the dealer or Auger Torque.

During the warranty period Auger Torque, at its option, will repair or replace any parts free of charge determined as defective by Auger Torque. Such repairs will be undertaken by Auger Torque or its nominated representative at an Auger Torque facility or a location deemed suitable by Auger Torque. Auger Torque are not liable for any associated costs relating to a warranty failure.

Parts repaired or replaced by Auger Torque are then covered by this warranty for the remainder of the original warranty as if such parts were original parts.

Products or parts which, as determined by Auger Torques examination, show wear from normal use, have been improperly operated, damaged by accident or negligence, altered or modified are not considered defective and are not covered by this warranty.

This warranty is void if any attempt is made to make field repairs unless these have been pre-approved in writing by Auger Torque. This includes, but is not limited to, disassembly, modifications to internal components, or any physical changes to the product.

This warranty is void if any third-party products or accessories are used that are not certified or recommended by Auger Torque. This includes the installation of any components, peripherals, or attachments that have not been expressly approved by Auger Torque.

This warranty is void if the products are not serviced in-line with the instructions in the Operators Manual. Particular care should be taken to perform regular oil changes in gearboxes.

This warranty is exclusive and in-lieu of any other expressed warranties. There are no warranties of merchantability or fitness for a particular purpose. Auger Torque shall not be liable for any consequential, incidental or punitive damages, losses or expenses, including those resulting from or caused by any defects.

As you would expect from Auger Torque, with our extensive experience and product reliability we'll always go the extra mile to keep you working.

11. EC Declaration of conformity



Manufactured by Auger Torque Europe Limited

EU Declaration of Conformity

The responsible person:

Name	
Position	
Company Name	<i>Auger Torque Europe Ltd.</i>
Address	<i>Hazelton, Cheltenham, GL54 4DX, England</i>
Telephone	<i>++44 (0) 1451 861652</i>
Fax	<i>++44 (0) 1451 861660</i>

Declares that the product described:

Manufacturer	<i>Auger Torque Europe Ltd.</i>
Model	
Serial Number	

Conforms to the Machinery Directive 2006/42/EC.

It also complies with the essential health and safety requirements, national standards and the transposed harmonised standards appropriate for this product.

Signed by:
(The responsible person)

Dated



YOUR DEALER IS

Auger Torque Europe Ltd

Hazleton
Cheltenham
GL54 4DX
England

Tel: +44 (0) 1451 861 652

Fax: +44 (0) 1451 861 660

Email: sales@augertorque.com

Auger Torque Australia Pty Ltd

481 Boundary Rd
Darra
Queensland 4076
Australia

Tel: +61 (0) 7 3274 2077

Fax: +61 (0) 7 3274 5077

Email: sales@augertorque.com.au

Auger Torque USA LLC

2640 Jason Industrial Parkway
Winston, GA 30187
USA

Tel: (+1) 844 287 6300

Fax: (+1) 770 947 9916

Email: sales@augertorqueusa.com

www.augertorque.com



Products and specifications subject to change without prior notice.

Some products may not be available in your country or region.

AUGER TORQUE, SHOCK LOCK™, NDS™ and the AUGER TORQUE LOGO are trademarks of Auger Torque Europe Ltd © 2024 Auger Torque Europe Ltd. All Rights Reserved.

25-07-2024